

ENHANCING ROAD SAFETY
AND ITS VISION. IT STAYS
COMMITTED
TO MANUFACTURE
QUALITY, INNOVATIVE AND VERSATILE
ROAD-SAFETY PRODUCTS.

PRODUCT CATALOGUE
2020



DARK EYE[®]

SALES & MARKETING :

3 - Masjid Road, Jangpura, New Delhi. 110014 (India)

Ph.: +91-11-2437 5335, +91-11-4167 5525

Mob : +91-93134-76024

Email : sales@darkeye.in , muskaansafety@gmail.com

LUDHIANA OFFICE :

1604 Kalsi Nagar, Dholewal Chowk, Ludhiana - 141003 (Punjab)

Mob : +91-93160-91932

Email : mso@tpmindia.com

The information in the catalogue was correct at the time of printing.
Dark Eye reserves the right to change specifications for further improvement
at any time without notice.

All The information provided in this catalogue are containing approximate values

concept By : www.shodowstudio.com

www.roadsafetyitems.com
www.darkeye.in



DARK EYE[®]

RESPECTING THE LIFE OF PEOPLE

- ROAD SAFETY CONES •SPRING POSTS •ROAD STUDS •SOLAR DELINEATORS •SOLAR BLINKERS
- SEARCH LIGHTS •GUIDE POSTS •REFLECTORS •SPEED BUMPS & RUMBLERS •SAFETY APPARELS •SIGNAGES
- ELECTRONIC SAFETY DEVICES • OTHER SAFETY DEVICES.

DARK EYE[®]

RESPECTING THE LIFE OF PEOPLE



"Safety, at all costs
Cloudy day or rainy night
Rush hour traffic or blinding lights."
ISO 9001-2008 CERTIFIED



Texla Plastics & Metals is an offshoot of a burgeoning industrial house in India that has been venturing in the Education and Entertainment world for more than four decades has already carved a sizeable niche for itself. Since its incorporation in 1990, it has ventured into manufacturing of plastic injection molded products, tools, dies and subsequently molded products for households, commercial and industrial applications. In 1998 TPM embarked on manufacturing road-safety products with the technical collaboration of our counter part in Korea.



Mr. Kawaljit Singh
MANAGING DIRECTOR

We Believe strongly in innovation and commitment to enhance safety of human beings on roads. DARK EYE has become the most sought-after road-safety brand in the domestic as well as overseas markets. Dedicated to its motto of enhancing road safety and its vision of staying committed to manufacturing quality, innovative and versatile road-safety products.

Our Mission

It is an avowed mantra for DARK EYE to emerge as the single most powerful brand in the arena of Road Safety.

Our Vision

We envision a highly safe road environment by committing ourselves to help the people drive, walk and get home safer.

Certification

Member of FIEO (Federation Of Indian Export Organisations)
MEMBER OF CII (Confederation of Indian Industry)



DARK EYE[®]

RESPECTING THE LIFE OF PEOPLE

Reduces road accidents by providing an advance warning.
 Its excellent reboundability quickly restores its original state without doing any damage to the vehicle as well as spring post.

SPRING POST

Made of special PU (Poly Urethane) material, it can quickly restore to its original state without damaging the vehicle and itself in case of a high-speed collision.

Highly reflective heat transfer sheet is pasted on specially designed grooves, making it highly visible from distance at night or in bad weather.

Its tensile strength and UV stabilizers enables it to withstand the harsh weather conditions. It is easy to install with epoxy and other strong adhesives without damage to roads or bridges.

Usage Areas

- Center Lane Dividing for narrow roads
- Multi lanes for broad roads
- Sharp Curves
- At the start of central verge (where single road becomes double road)
- Traffic Islands
- No Stop Zone at T shape road
- traffic signals
- Parking lots
- Construction Zones
- No Entry Zones
- Dangerous medians and 'U' Turn etc



Model No. : DA 963

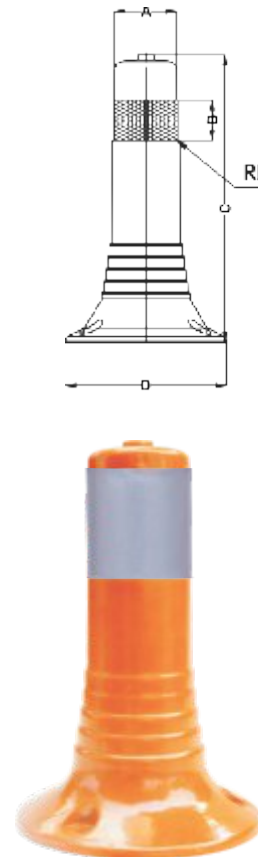
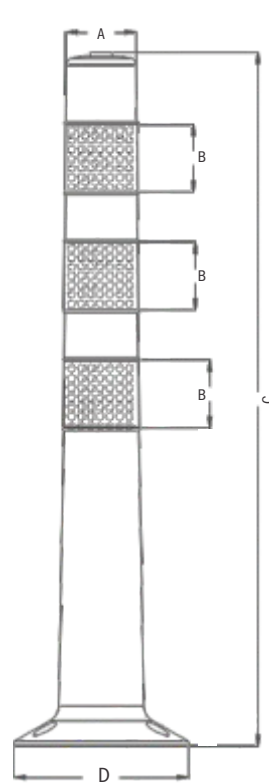

Model No. : DA 960

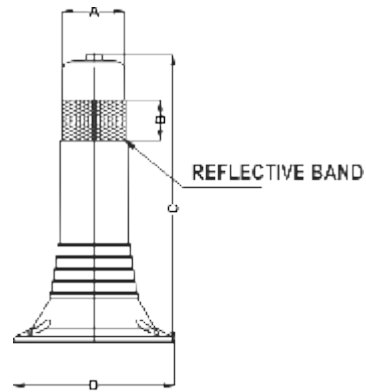

Model No. : DA 961

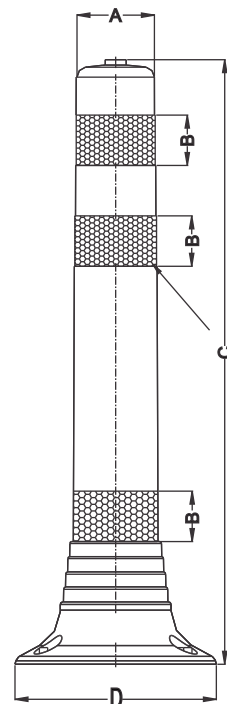

04



Model No. : DA 962

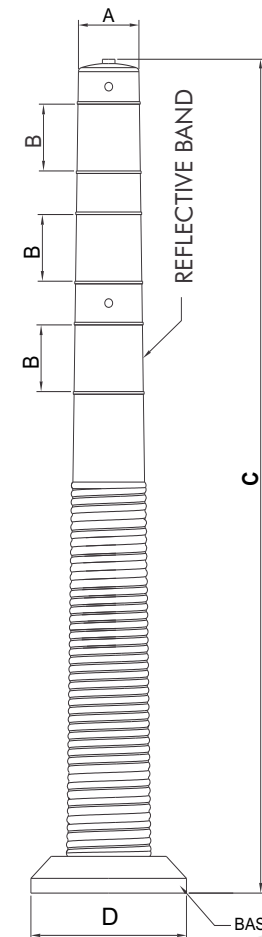

05

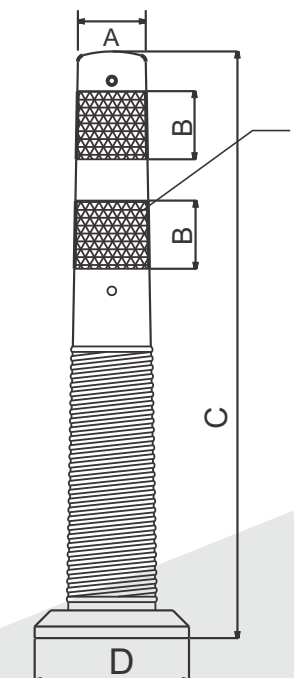

Model No. : DA 954



HOOK (OPTIONAL)

Weight : 10 Grams

MODEL NO	A DIA	B TAPE SIZE	C HEIGHT	D BASE DIA	WEIGHT
DA 954	80	80	710	200	1600
DA 960	80	50	300	195	600
DA 961	77	50	600	195	990
DA 962	77	80	970	200	1800
DA 963	80	78	800	200	1200



DARK EYE®

RESPECTING THE LIFE OF PEOPLE

ULTRAFLEX POST

The Ultraflex Post is designed to protect your work zone under the most demanding conditions. The perfect combinations of durability, visibility and simple installation helps you to save time and money maintaining your lane diversions. Design to meet Indian conditions, the ultraflex post will help to improve your road safety.

Features & Benefits

- Superior durability for lower maintenance
- Bright Color and high quality reflective for greater visibility, Day and Night
- A single pin for easy installation
- Can be glued or bolted
- Unaffected by outdoor temperature variations
- Can with stand impact in excess of 100 Kph
- Made from PU (Poly Urethane)

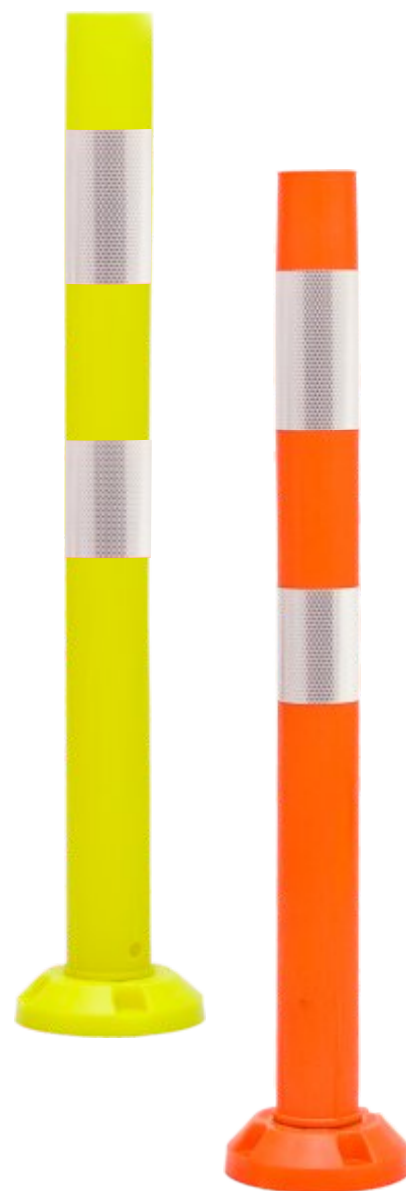
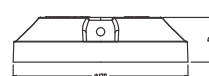
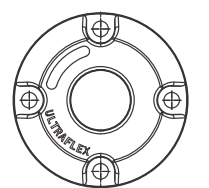
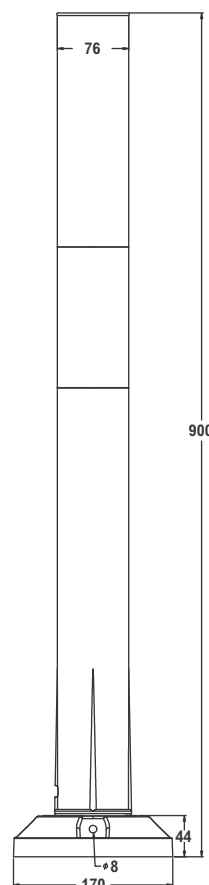

MODEL NO. : DA 965
(ULTRAFLEX POST)
WEIGHT : 1350 GM



06

ULTRAKERB

Ultrakerb giving new ideas/ways to divide roads, paths due to its light weight, modern and Internationally accepted design. It can be installed in minutes.

- Ultrakerb and Ultraflex post can be attached easily using a single aluminum pin.
- Attractive and Internationally Accepted Design
- End Pieces (Edges) can be attached as and when required.
- A cap is provided if ultraflex post attachment is not required.
- Available in White, Yellow, Orange, Blue & Black Colors

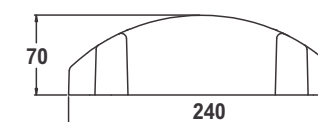

Dimensions: 740 x 70 x 240mm
Ultrakerb Material: PE

ULTRAFLEX Post (optional)
Post Height : 800 M
(Installed on the Verge)

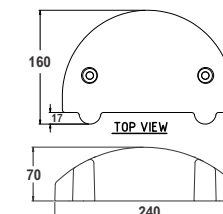
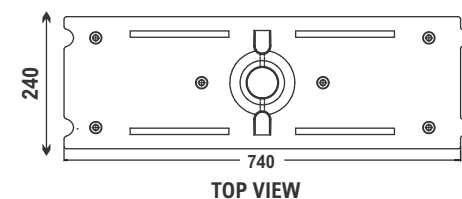

MODEL NO. : DA 1015 (Edge)
Weight : 370 Grams each

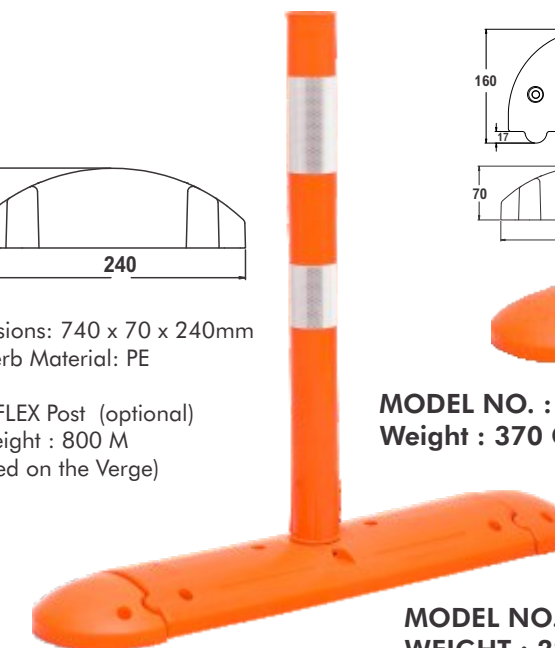

MODEL NO. : DA 1014
WEIGHT : 2200 GM

CENTRE VERGE

- Centre Verge is useful to make dividers to control the traffic.
- Manufactured in PE, U.V Stablized material.
- Instant fixing and portability makes it suitable to control traffic.
- Spring Post (Model DA 954 & 962) can be easily fixed into the Centre Verge
- Available in White, Yellow, Orange, Blue & Black Colors
- Size : Length 740 mm & Width 250 mm Weight 2250 Grams.

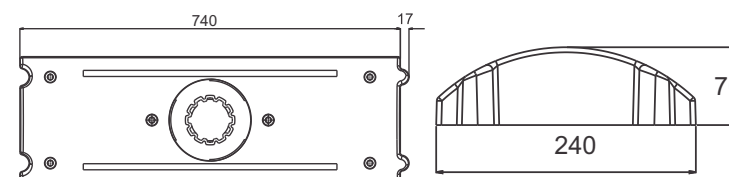

MODEL NO. : DA 1011
WEIGHT : 2350 GM

LANE DIVIDER

Lane Divider is innovative and cost effective concept to divide roads and paths due to its light and durable construction.

- Internationally Accepted Design
- Available in White, Yellow, Orange, Blue & Black Colors

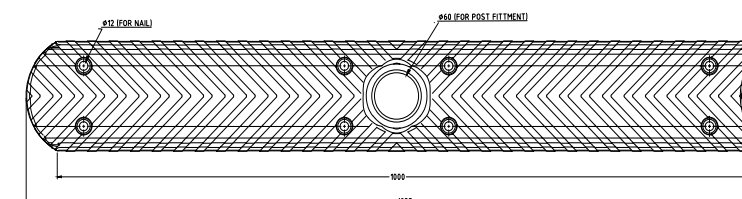

MODEL NO	HEIGHT	WEIGHT
DA 965	900	1350
DA 1014	70	2200
DA 1011	70	2350
DA 1017	42	1660

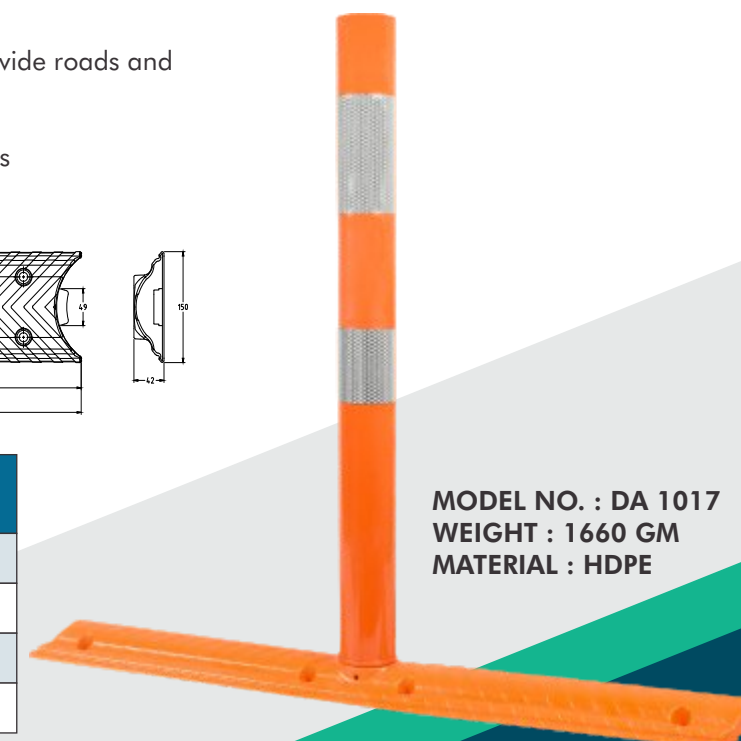

MODEL NO. : DA 1017
WEIGHT : 1660 GM
MATERIAL : HDPE

07

GUIDE POST

T-Top and Loop Top guide posts, also called bollards are excellent visual demarcations which can be used at hospitals, shopping malls, schools, parking lot etc.

These Guide Posts are designed for maximum visibility, quick setup and low maintenance, these delineator posts feature a 'flare-bottom' design.

Guide Post bases are made from high quality non fading rubber base. Guide post include two sets of highly reflective tapes.

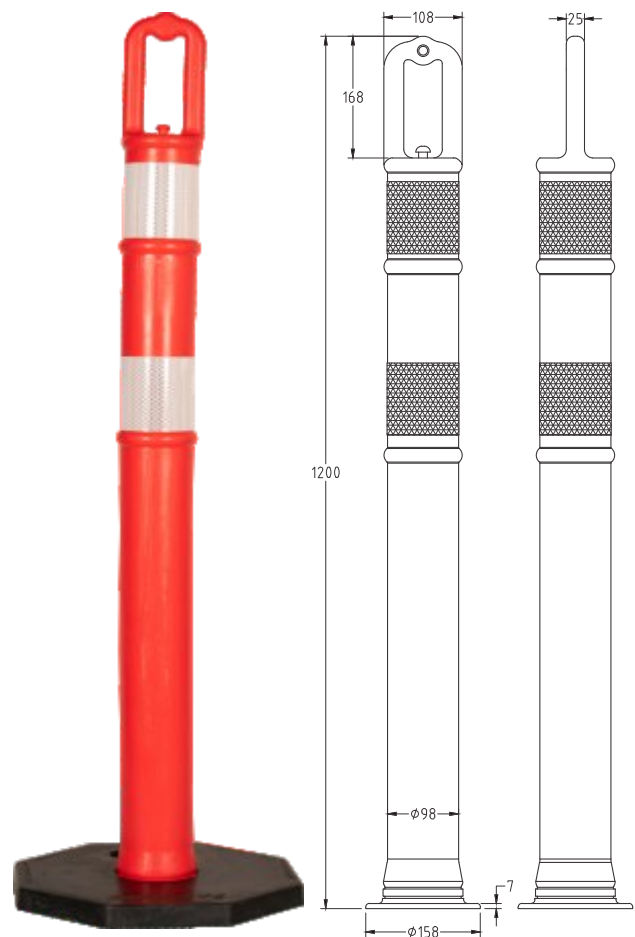

MODEL NO. : DA 824 (LOOP TOP GUIDE POST)
WEIGHT : 5.5 Kg
MATERIAL : HDPE

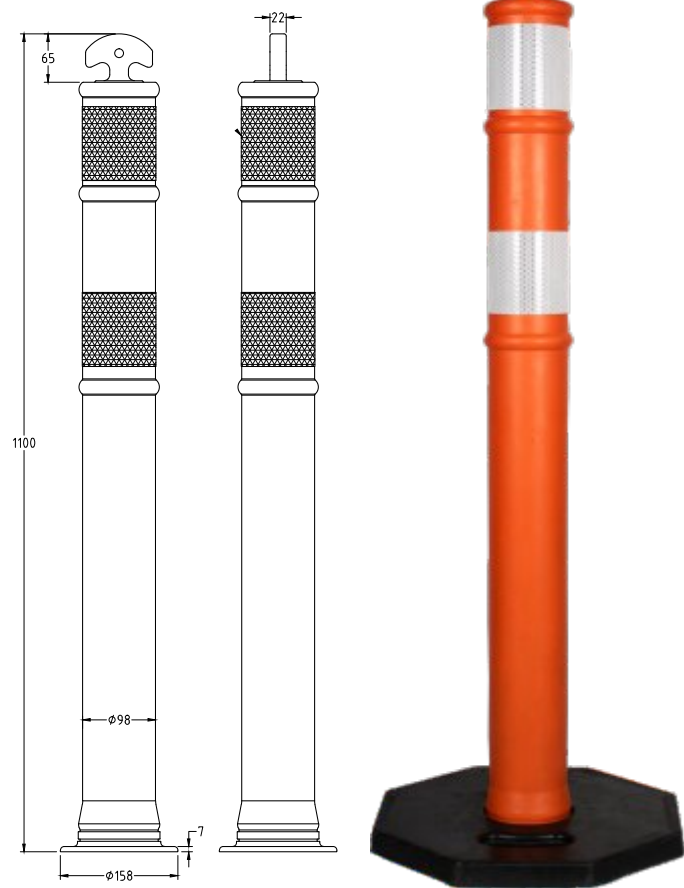

MODEL NO. : DA 823 (T-TOP GUIDE POST)
WEIGHT : 5.4 Kg
MATERIAL :- HDPE

Features & Benefits

- Can be interlinked with plastic chains
- Specialized HDPE construction
- Includes Reflective Strips
- Suitable for indoor and outdoor applications
- UV stabilized
- Highly effective in road traffic management

MODEL NO	HEIGHT	WEIGHT
DA 823	1100	4800
DA 824	1200	4850
DA 953	1400	2000
DA 964	800	1230

GUIDE POST

• Two high performance 100 mm reflectors are positioned above the road surface in order to provide safe and comfortable eye guidance.

• It has a white reflector in the direction of one lane and a yellow reflector in the direction of opposite lane to provide good visibility.

• Posts are used to guide the edges of the highways and narrow roads.

MODEL NO. : DA 953
HEIGHT : 1400
WEIGHT : 1700
MATERIAL : HDPE

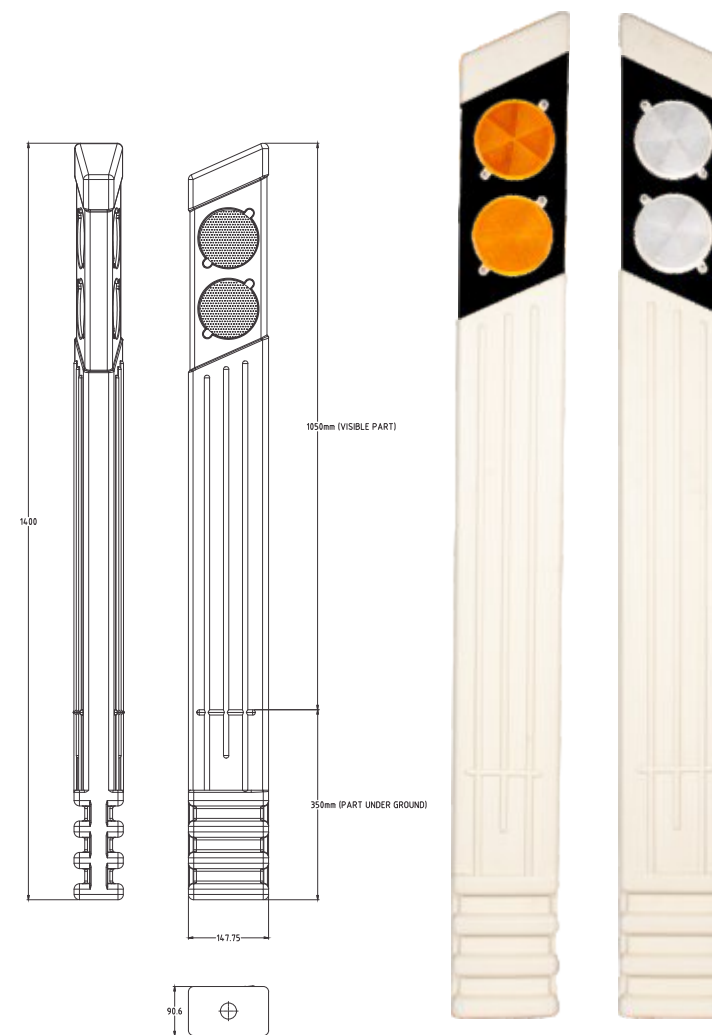

GUIDE POST

Features & Benefits

- Reflector of 100mm dia fitted on both sides
- Bright color and high quality reflective for greater visibility, day and night
- Easy installation
- Can be glued or bolted
- Unaffected by outdoor temperature variations
- UV stabilized

MODEL NO. : DA 964
HEIGHT : 800 MM
WEIGHT : 1230 GM
MATERIAL : HDPE

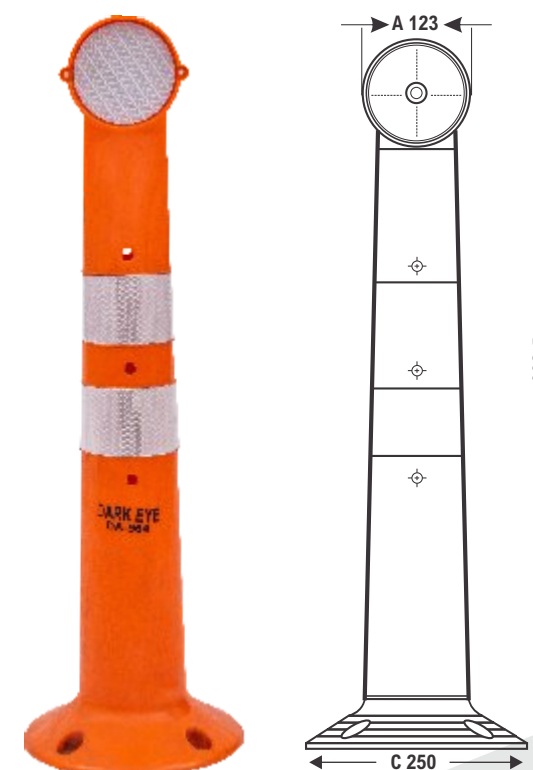

SPEED BUMP

Dark Eye speed bumps are highly resistant to severe impacts and harsh weather conditions. Its interlocking sub units make it bind perfectly into a one firm bump.

The pre-colored material (Black/Yellow) and UV stabilizers keep them perpetually colorful, Studded with reflectors on either side, they are clearly visible to the motorists during night hours. These bumps are ideal for Private Colonies, Hospitals, Educational Institutes, Security Check Posts, Parking Areas, Loading Sites, Factory Complex or anywhere it is desired to control the speed of moving vehicles.



MODEL NO. : DA 1004
HEIGHT : 75 MM
WEIGHT : 2180 GM
MATERIAL : HDPE

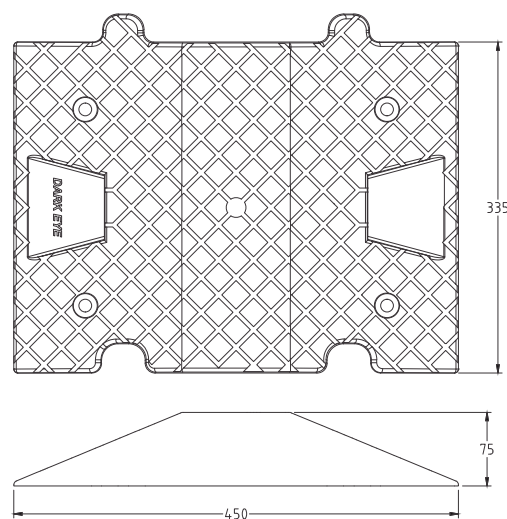

Installation Procedure : Clean the surface, mark the nail points, grout the holes and clean the surface again. Apply appropriate epoxy the 6 nails provided with the Bumps.

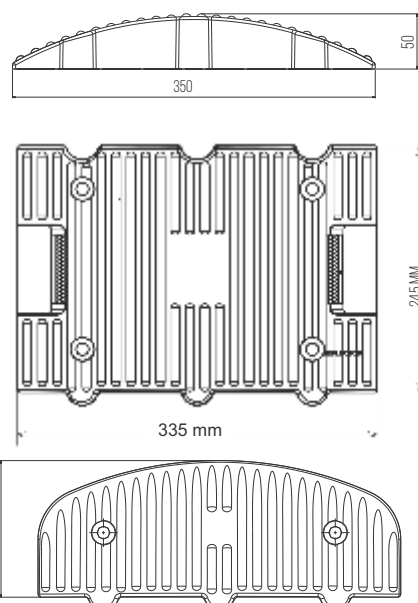

EDGE



MODEL NO. : DA 1005
SPEED BUMP 50 MM
DESIGN PATENT NO. : 202374
WEIGHT : 1070 GM
MATERIAL : PE

SPEED BUMP

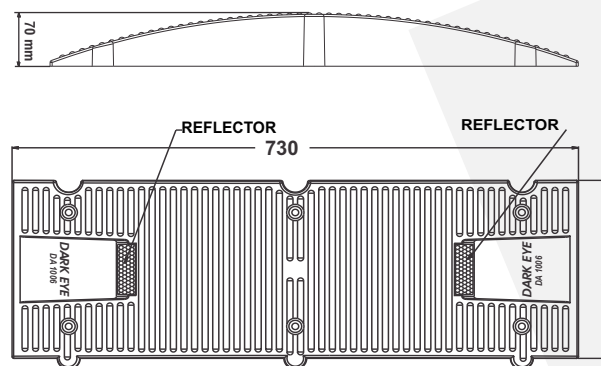

MODEL NO. : DA 1006
HEIGHT : 70 MM
DESIGN PATENT NO. : 206431
WEIGHT : 2160 GM
MATERIAL : PE

MODEL NO. : DA 1008
SPEED BUMP : 50 MM
WEIGHT : 2600 GM
MATERIAL : PE

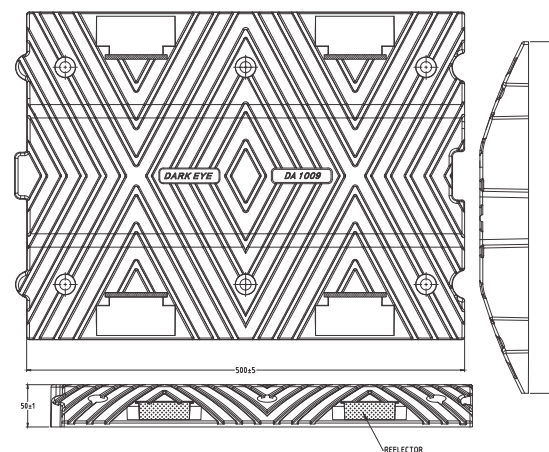
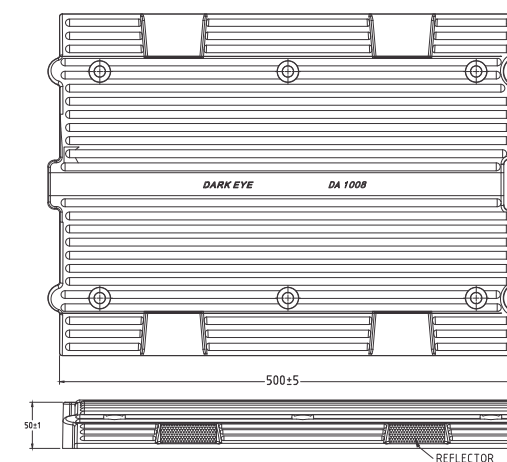
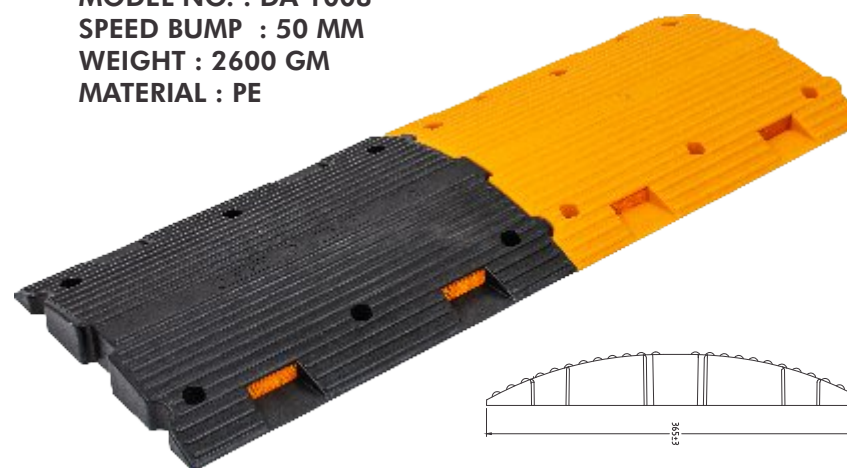

MODEL NO. : DA 1009
HEIGHT : 50 MM
WEIGHT : 2520 GM
MATERIAL : HDPE

POTABLE SPEED BREAKER

- Portable speed bump is designed to control temporary traffic pattern
- Speed bumps fold up and fit into storage bag (included) when not in use
- High visibility black and yellow design features multiple reflectors for added visibility at night
- The inter locking individual pads allow it to naturally conform to the road surface which reduces stress and increase longevity
- Comes with built in handle for easy placement
- Can be easily transported and stored

IDEAL FOR :-

- School zone safety
- Civic activities
- Security check point
- Street fair
- Easy storage and transportation

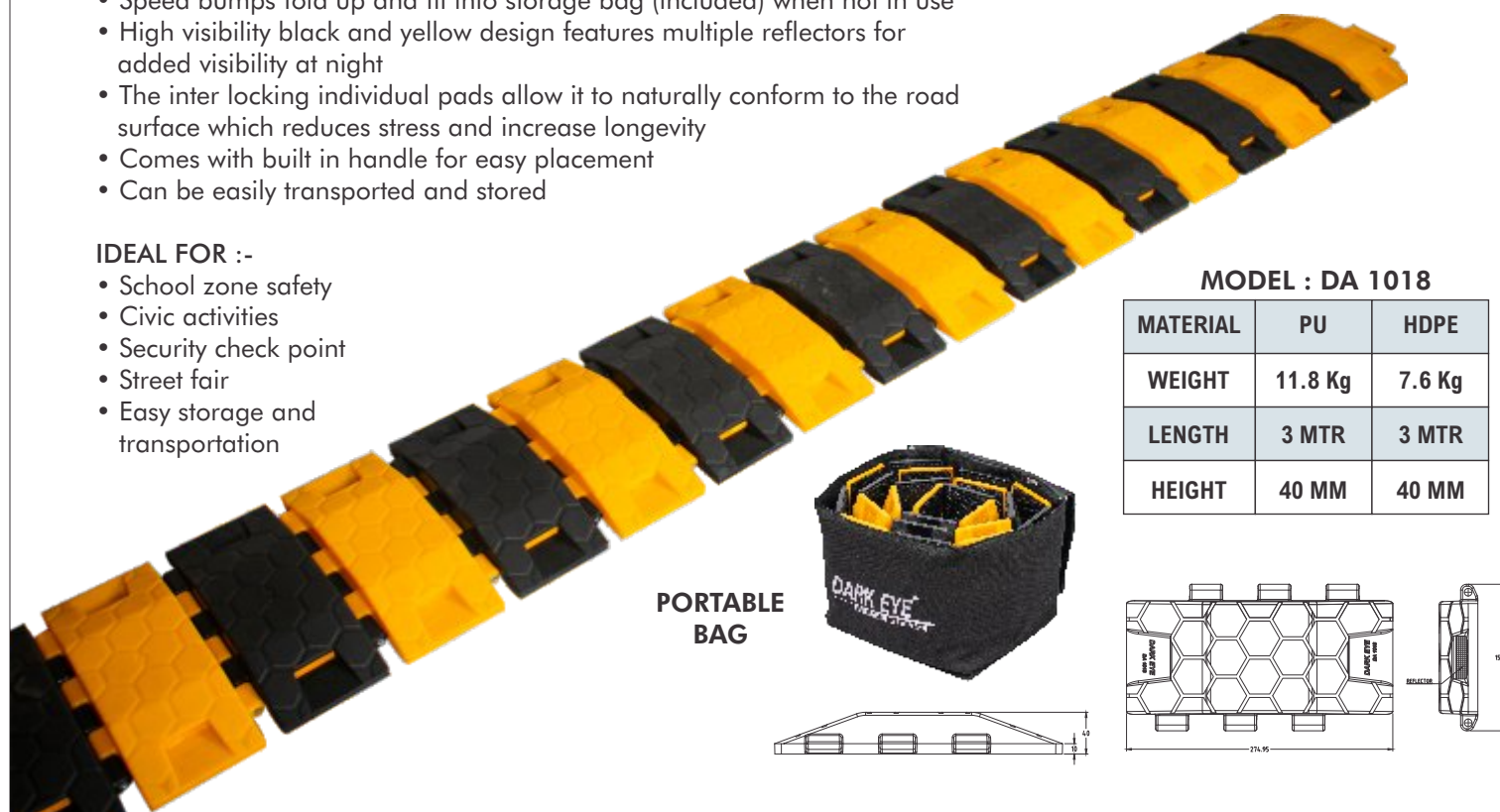

MODEL : DA 1018

MATERIAL	PU	HDPE
WEIGHT	11.8 Kg	7.6 Kg
LENGTH	3 MTR	3 MTR
HEIGHT	40 MM	40 MM

RUMBLER

Rumbler strips, also known as alert strips, wake up calls, growlers and drift lines, are a road safety feature to alert inattentive drivers of potential danger, by causing a tactile vibration and audible rumbling transmitted through the wheels into the vehicle interior. A rumble strip is applied along the direction of travel following an edgeline or centerline, to alert drivers when they drift from their lane. Rumble strips may also be installed in a series across the direction of travel, to warn drivers of a stop or slowdown ahead, or of an approaching danger spot.

- MODEL :- DA 1003**
WEIGHT :- 480 GM
HEIGHT :- 15 MM
LENGTH :- 500 MM
MATERIAL :- PU

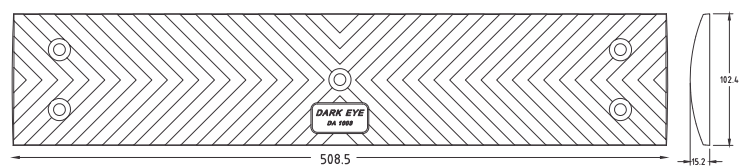

ANTI GLARE

Antiglare Screen/panel/board are installed on the highways where speeds are generally in excess of 70 Km/hr as these block glare.

It comes with special antitheft bolts and is specially designed to block head lights from opposite side. Antiglare screens are crucial in improving highway safety.

Key Features :-

- Easy to install
- Possible to mount on any guardrails
- Reflectors of 100mm Dia on each sides
- Light weight, UV stabilised,
- High intensity and Anti-corrosion property

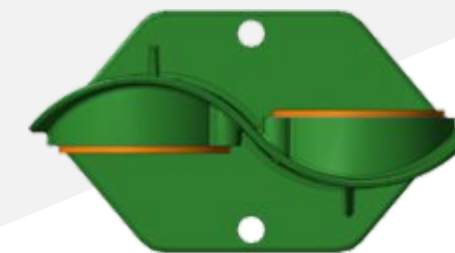

MODEL :- DA 78
WEIGHT :- 1560 gram.
MATERIAL :- HDPE

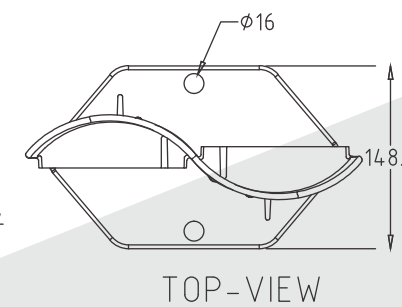
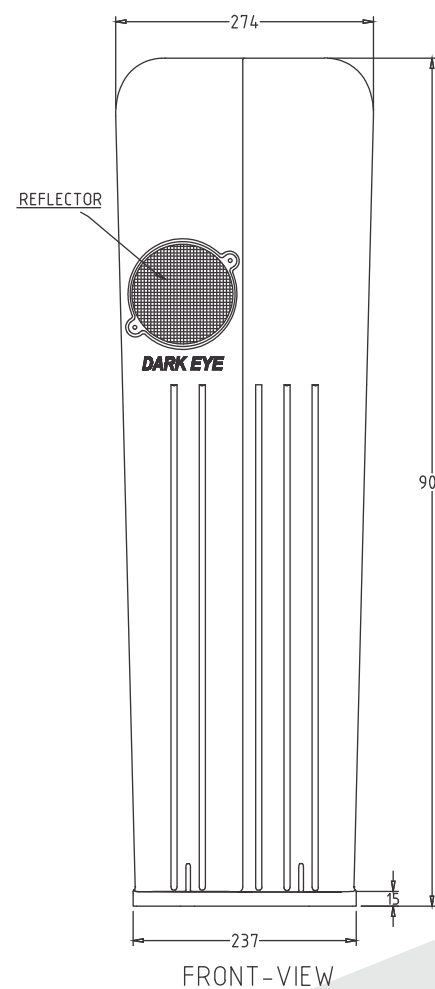

TRAFFIC CONES

- Road safety cones meet world-class quality standards. Made up of high quality LDPE (Low Density Poly Ephylene) using UV stabilizers, these cones remain unchanged in color, in all weather conditions. Their bright hues make them visible from distance.
- Fitted with highly reflective sleeve, these cones can be used for traffic monitoring. Quite versatile, these Cones are compatible with various types of road safety accessories such as barricade tape, Plastic chain, safety light bar, message plates, Flags etc.
- Provided with In built heavy rubber base at the bottom, these cones remain intact in heavy wind pressure.

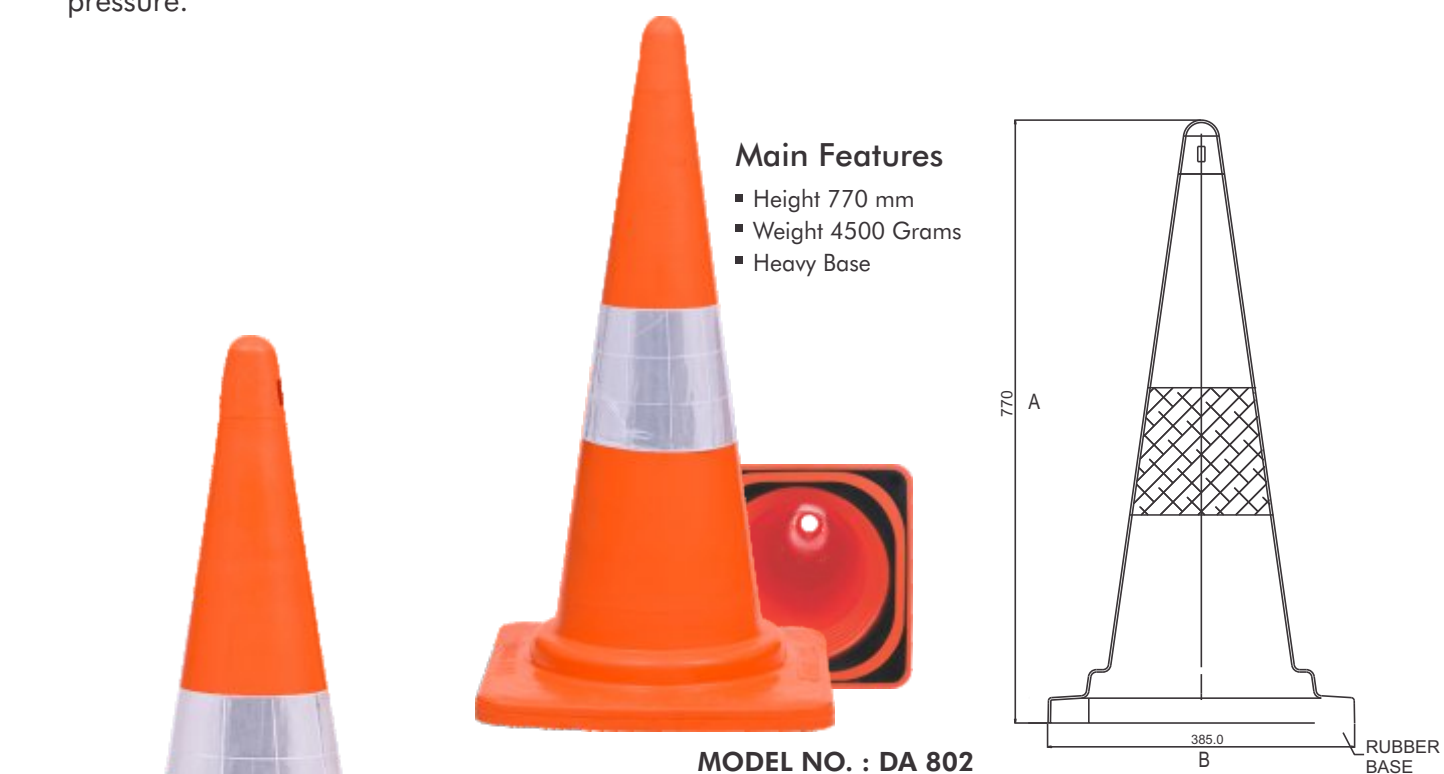

Main Features

- Height 770 mm
- Weight 4500 Grams
- Heavy Base

MODEL NO. : DA 802



Model No. : DA 815

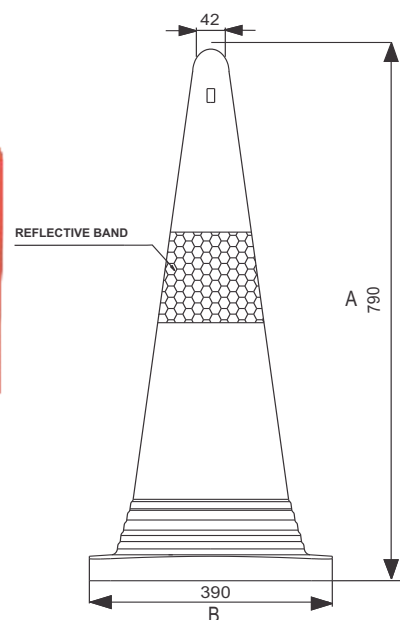

Main Features

- 790 MM Height
- Use With Other Accessories Like Light Bar, Reflector, Message Plate
- Square Base : 395 x 395
- Weight : 3583 Grams (with rubber base)

TRAFFIC CONES

Heavy weight rubber base enables it to stand upright in fast winds or traffic.



Main Features

- 1000 MM Height with cap
- Use With Other Accessories Like Light Bar, Reflector, Message Plate
- Heavy Base
- Weight : 5560 Grams

Model No. : DA 814

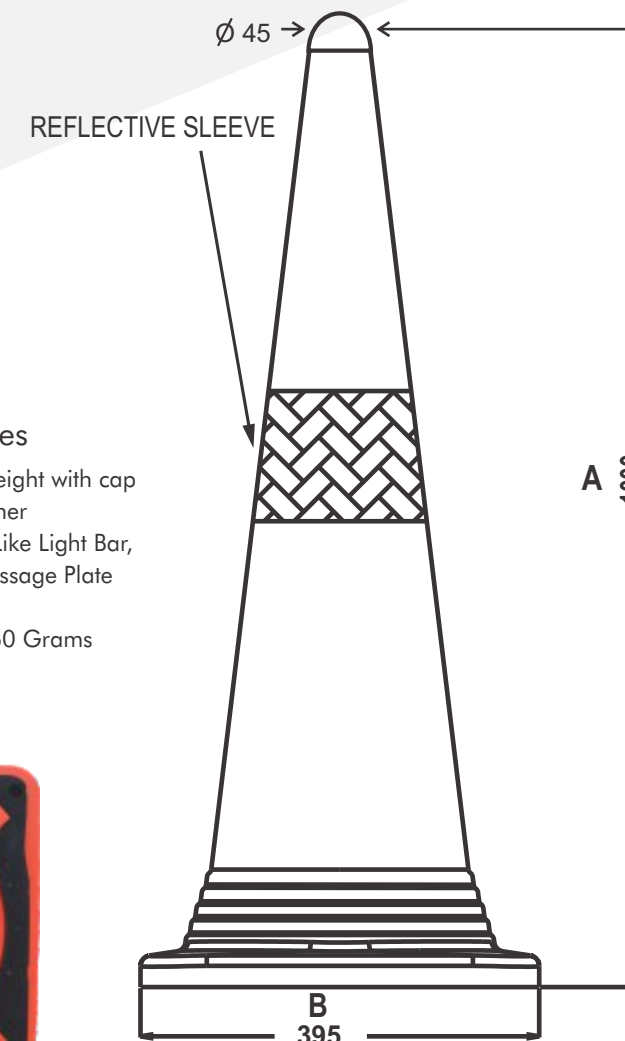

Model	Height A	Base B	Weight (Gms) (Approx.)
DA 801	710	395 x 395	1220
DA 802	770	395 x 395	4500
DA 803	715	420 x 3 sides	1770
DA 814	1000	395 x 395	5200
DA 815	790	395 x 395	3700
DA 816	1000	450 x 450	6300

TRAFFIC CONES

- Triangular Cones meet world class quality standards. Injection Moulded from LDPE plastic, using UV stabilized material, these cones can withstand all weather conditions.
- Fitted with reflective sleeve, these cones can be used for traffic controlling, construction sites, airports, parking areas etc.
- Built in hook can be used for various purposes.
- These cones are easily stackable.

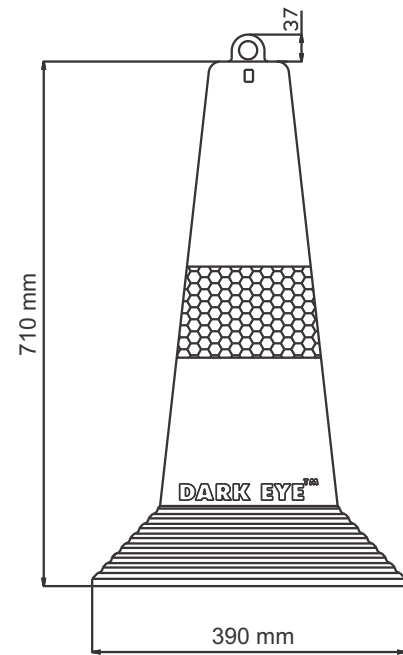

MODEL NO - DA 803
HEIGHT : 710
Weight : 1770 Grams



- These cones are made from blow moulding process with attached rubber base.
- It guarantees the quality and stability of colour in all weather conditions because of UV stabilized material.

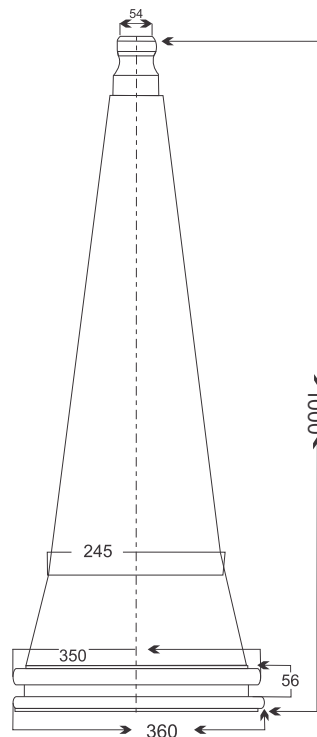

Model No : DA 816
HEIGHT : 1000
WEIGHT : 5000 GM
HEAVY BASE : 6300 GM



AIR CONES

This uniquely designed safety cone is light-weighted, sturdy, portable and able to resist high pressure winds, due to its aerodynamic design.

It is constituted by high quality materials including unique rubber base and also Cone is UV stabilized, to ensure top notch quality and stability of the colour.

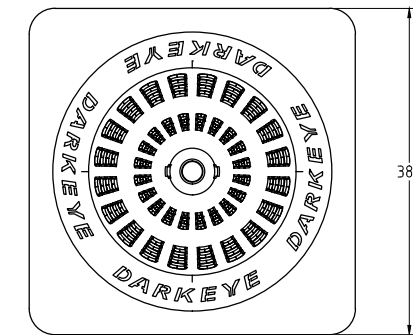

MODEL NO - DA 807
HEIGHT : 800
Weight : 3500 GM

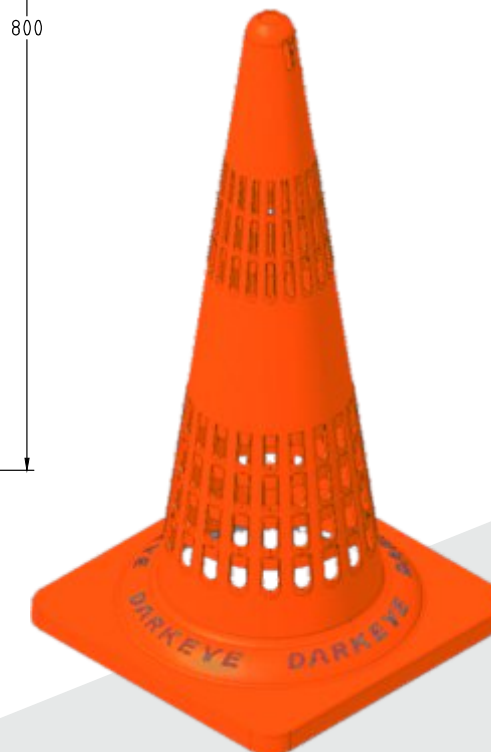
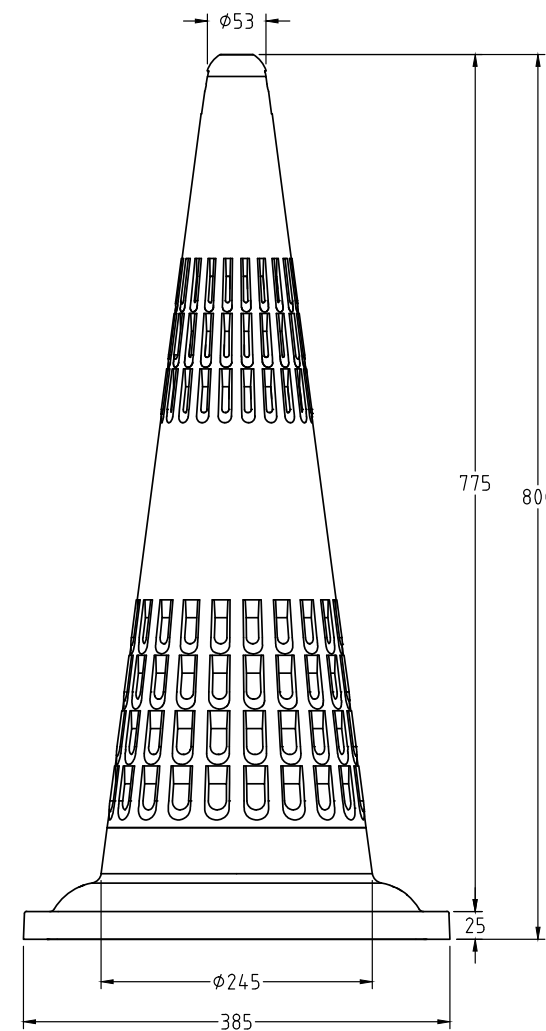
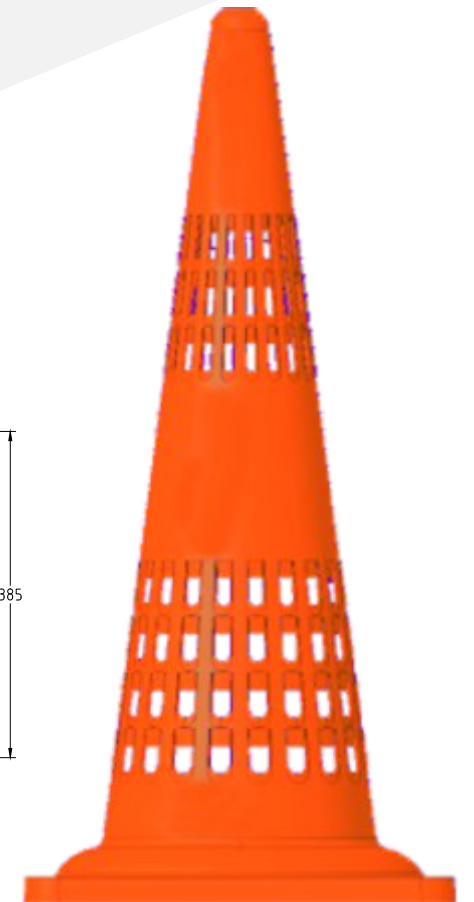

COLUMN GUARD

MODEL NO : DA 1013
WEIGHT : 4260 GM
MATERIAL : RUBBER

Supply of column guard made out of rubber material, 8 mm thick, with yellow reflective tape.

Available in Size: 800 mm, 900 mm, 1000 & 1250 mm

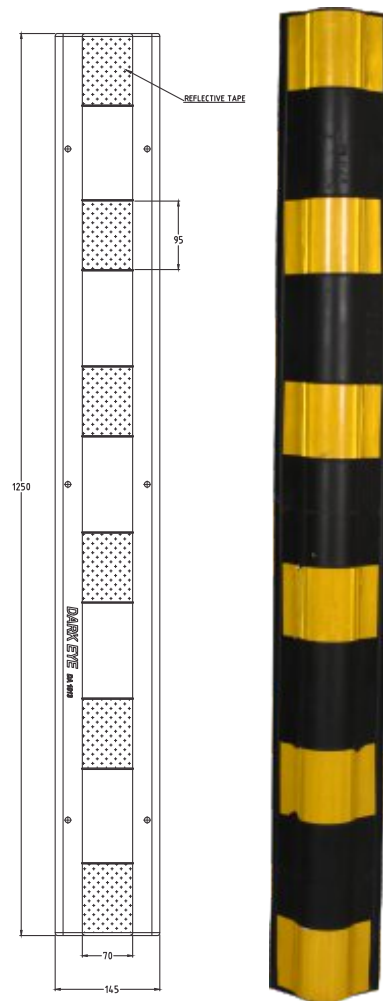

WALL GUARD

MODEL NO : DA 1019
LxWxH : 1000mm X 200mm X 30 mm
Weight : 5.5 Kg. Approx.
Material : Rubber



Wall Guard is made out of soft rubber material. Two bands of reflective tape is provided for better visibility

CAR STOPPER

Car Stopper helps ensure vehicle stop at the proper location while parking - preventing damage to buildings, sidewalks, curbs and delicate landscape. Ideal for retail / commercial / business parking lots, parking garages and municipalities.

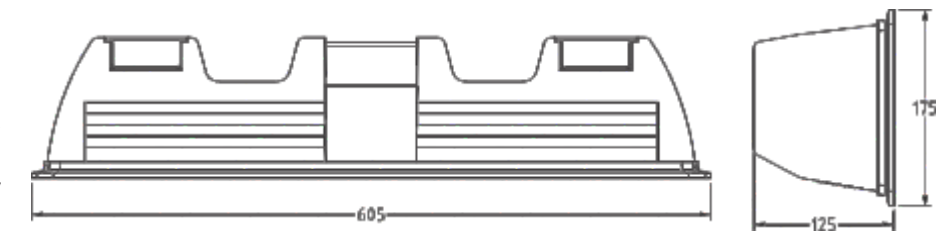

MODEL :- DA 1016
MATERIAL :- HDPE
WEIGHT :- 1400 Gm



WHEEL CLAMP

The Wheel Clamp is suited for cars, vans, jeeps etc. It has a corrosion resistant hardened steel construction and suitable for locking tyres up to 275 mm width. The minimum width of the clamp when closed is 35 mm and maximum width of the clamp when opened is 275 mm.

The clamp handle length is 220mm and the maximum height is 60 mm. The handle is PVC coated for a comfortable grip. The forks of the clamp are PVC coated to save the vehicle wheel rims from any scratches while locking and unlocking of the clamp. The wheel clamp has an internal locking system and has a total weight of approx. 2.0 Kgs.



CONVEX MIRROR

Available Size :
 480 mm
 600 mm
 800 mm
 1000 mm



TRAFFIC BARRICADES

Darkeye Barricades creates a barrier or obstacle to control, block passage or force the flow of traffic in the desired direction.

Our Barricades are specifically designed for crowd control purpose and are very good alternatives for cemented barrier to use at toll plaza and highways. These can be used at shopping malls, stadiums, airports and anywhere for organising traffic and road safety purposes.

They prevent vehicles from heavy damages during a crash and can be water or sand filled, to improve it's stability.

Key Features:-

- UV stabilised for excellent colour stability
- Can be interlocked in long series, curves or any geometric shapes as per requirement
- Sturdy long lasting design
- Astheically appealing

Uses :- Shopping Malls , Stadiums, Toll Plazas, Airports, Bus Stands, Hotels, Hospitals etc.



Model - RB-1 (Red)
1600 x 650 x 980 MM



Model - RB-2 (Red)
1055 x 500 x 800 MM



Model - RB-3 (White)
1030 x 150 x 500 MM

TRAFFIC BARRICADES

- Portable plastic traffic barricades are more effective, safe and stable than drums, posts, cones and other types of temporary barricades.
- High visibility alerts drivers to safety hazards ahead.
- It can be aligned in a straight or in twisting roads.
- Linear design makes a positive visual separation between vehicles, bicycles and pedestrians.
- Custom signage and flashers can be easily attached on it.

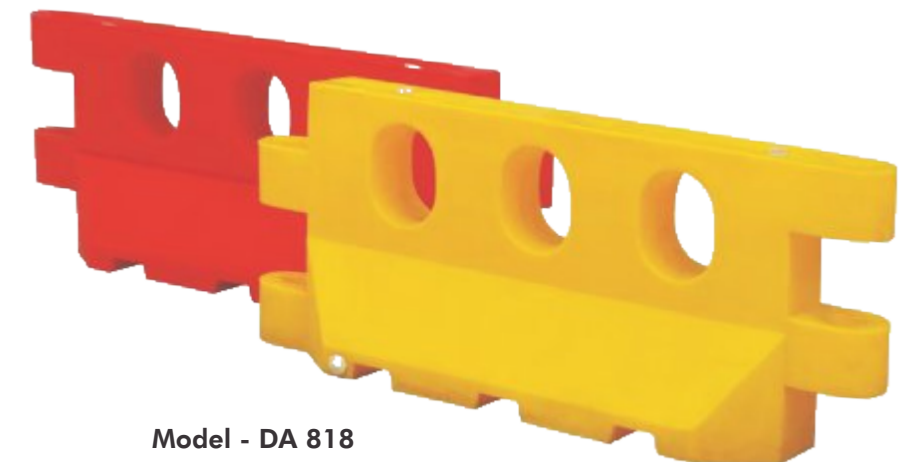
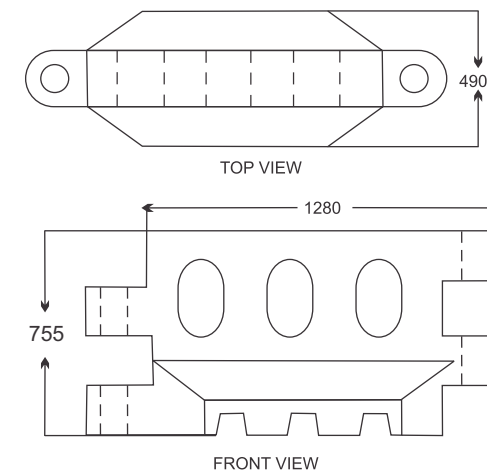

Model - DA 818

BULL NOSE

Made out of LLDPE material, Size: L: 1200, W: 480 mm (front), 1370 mm (Back), Back Height: 1000 mm, Front Height: 970 mm, Water Ballast: 650 ltrs

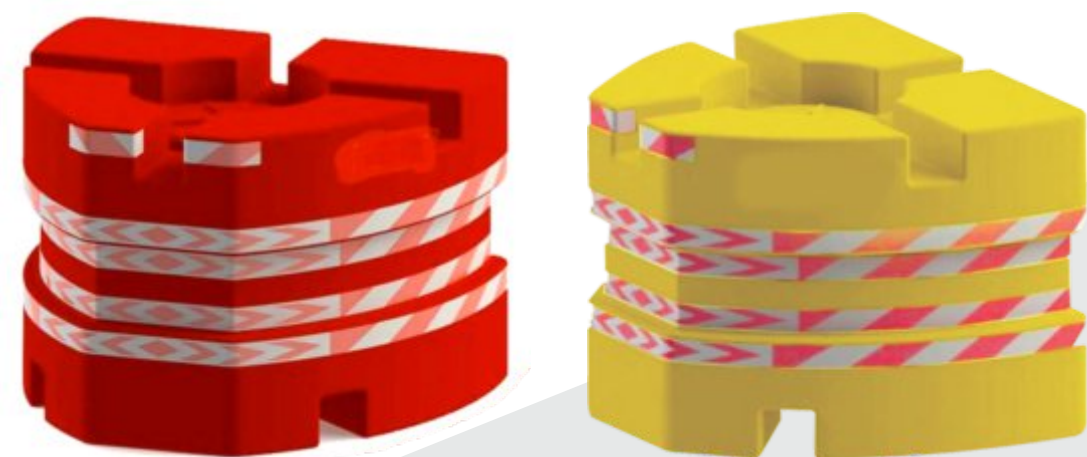

Model - RB-4

BARRICADE CONNECTOR

Dark Eye Barricade Connector are made out of special grade (LLDPE) in orange colour by Roto Moulding Process.

Reflectors / Tape can be fitted on it for better visibility in the night.

TRAFFIC BARRICADES



Model - DA 819 PLANK
Weight : 1800 GM
Material : ABS
LENGTH : 980 MM

Traffic Barricade Application :

- Lane delineation, diversion of traffic etc.
- Sidewalk detour
- Sports, crowd control etc
- Parking lots
- Terminals – ferry, freight, airport
- Toll booths
- Police and other security purpose
- Temporary hazards, closures



Model - DA 817
Weight : 2520 GM
Material : HDPE
HEIGHT : 750 MM

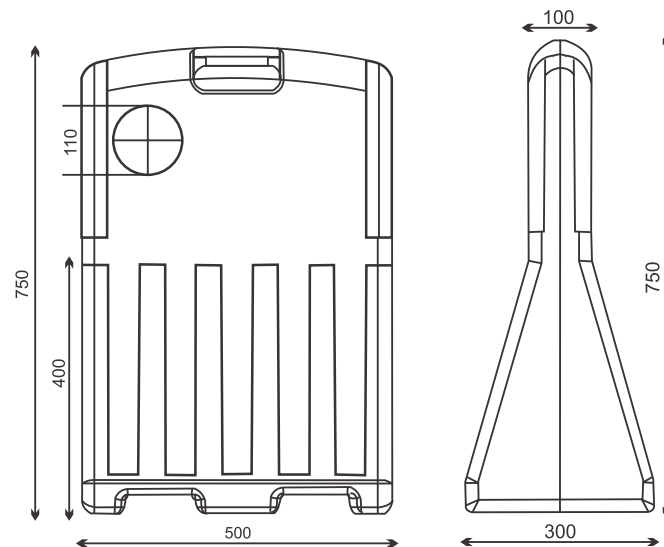

ANGULAR JOINER



STRAIGHT JOINER

ANGULAR JOINER

- Joiner interlock barricades and stays together securely.
- This is used to connect barricades to get desired angle.
- This can be used to create a round about by interlocking the barricades

STRAIGHT JOINER

- It is used to inter lock barricades in straight line.

TRAFFIC BARRICADES

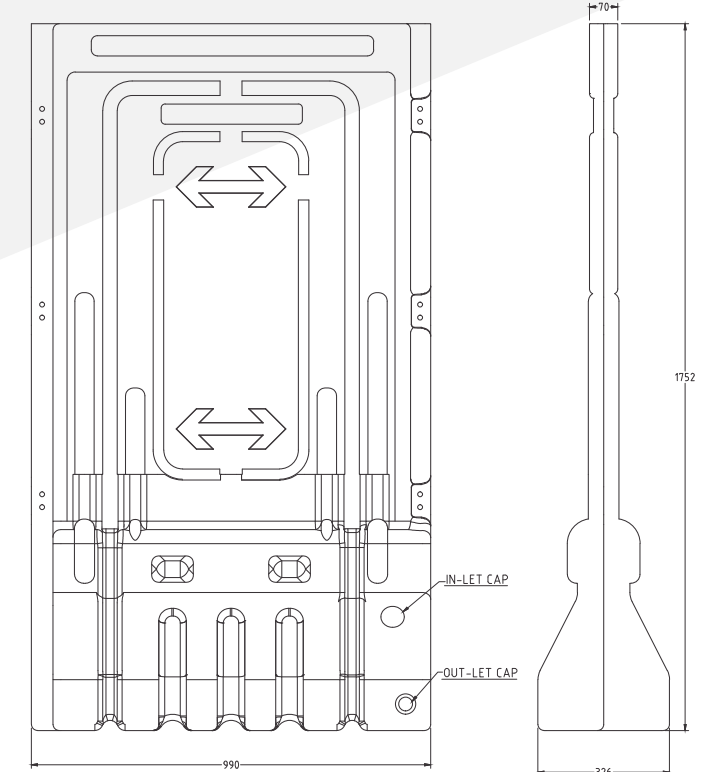

Model - DA 820
Weight : 11.00 KG
Material : HDPE
HEIGHT : 1750 MM

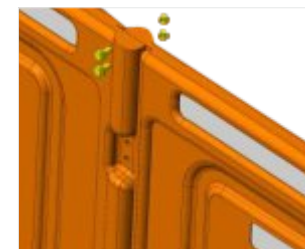

TRAFFIC BARRICADES

TRAFFIC BARRICADES



Model - DA 821
Weight : 7500 GM
HEIGHT : 1473 MM
MATERIAL : HDPE
WATER CAPACITY : 80L

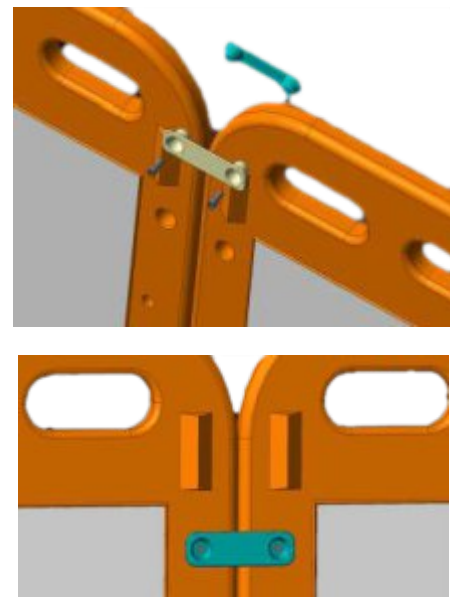
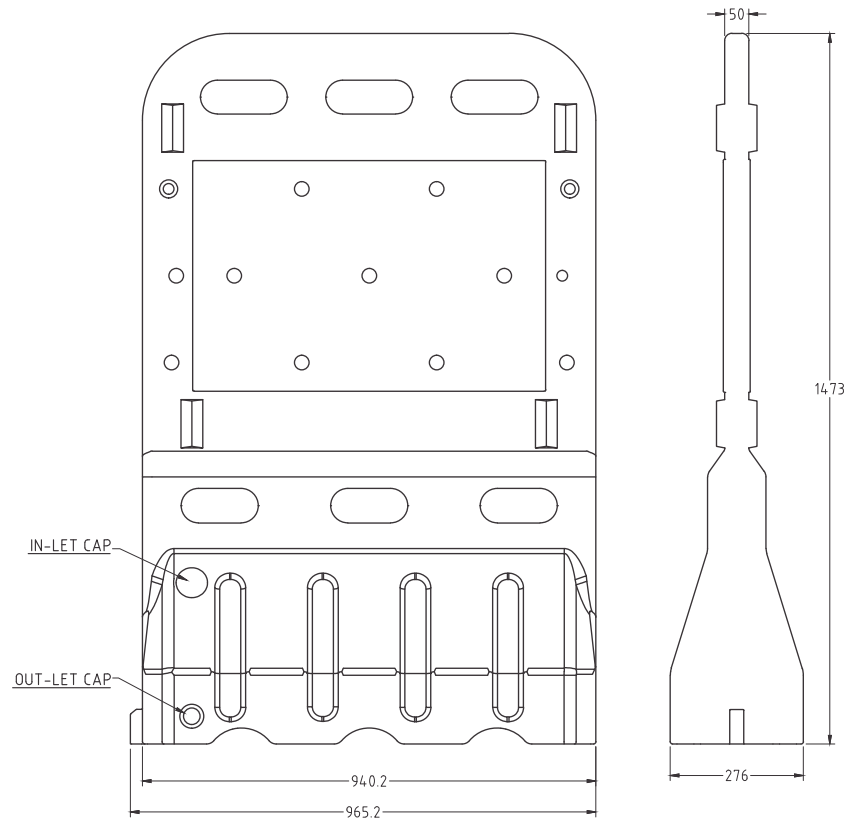

Model - DA 822
Weight : 8500 GM
HEIGHT : 1220 MM
MATERIAL : HDPE

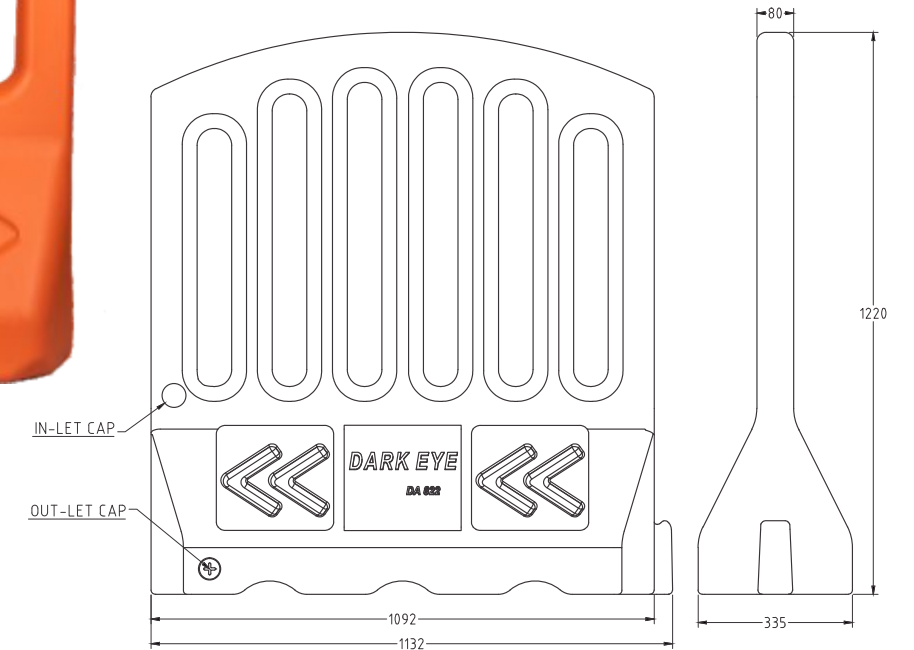

DELINEATORS

- Delineators are ideally suitable for dangerous curves, central verges, Islands etc.
- High quality round reflectors fixed on both sides make it highly visible in poor light condition.
- They can be installed horizontally as well as vertically.
- Due to specially designed body and reflectors fixation method, their reflectivity and durability remain for a long life.



MODEL NO. :
DA 74

MODEL NO. : DA 74

- Two high performance 100mm Dia reflectors and two rectangular reflectors of 70mmx23mm are fixed on both sides of Guide Post.
- Reflectors are positioned at the best eye guiding level, so that drivers can be warned from a safe distance.
- The body of Guide Post is moulded in ABS plastic and it is fixed on powder coated steel pipe of 1010 mm height.
- Weight 1760 Gms. (Approx.)

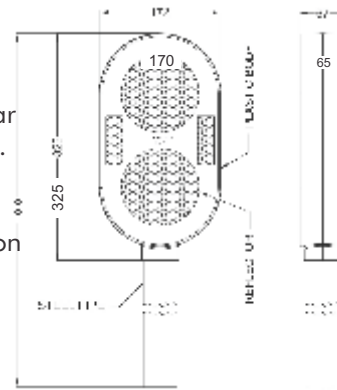

MODEL NO. :
DA 952 GP

MODEL NO. : DA 952 GP

ABS round body fitted with 2 Nos 100 mm or 65 mm dia highly reflective reflectors made out of PMMA and mounted on MS pipe of 50 duly powder coated, anti rust & anti theft steel net.
Available in Red, White or Yellow, White combination.
Weight : 765 Gms. (Approx.)



DELINEATORS



MODEL NO. : DA 76

MODEL NO. : DA 76

ABS round body fitted with 2 nos. of 100 mm Dia highly reflective reflectors made of PMMA material mounted on powder coated rectangular steel pipe having size 1" x 3" x 24".

Available colour are Red, white and Yellow.

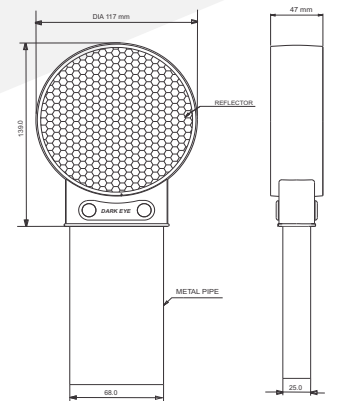

MODEL NO. : DA 77

MODEL NO. : DA 77

ABS Rectangular body fitted with 2 nos. of 105 x 85 mm size, highly reflective reflectors made of PMMA material mounted on powder coated rectangular steel pipe having size 1" x 3" x 24".

Available colour are Red, white and Yellow.

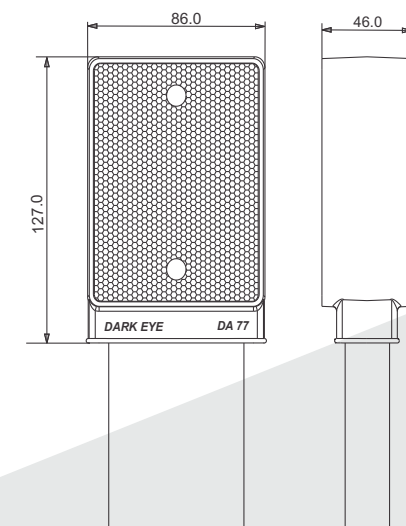

DELINEATORS

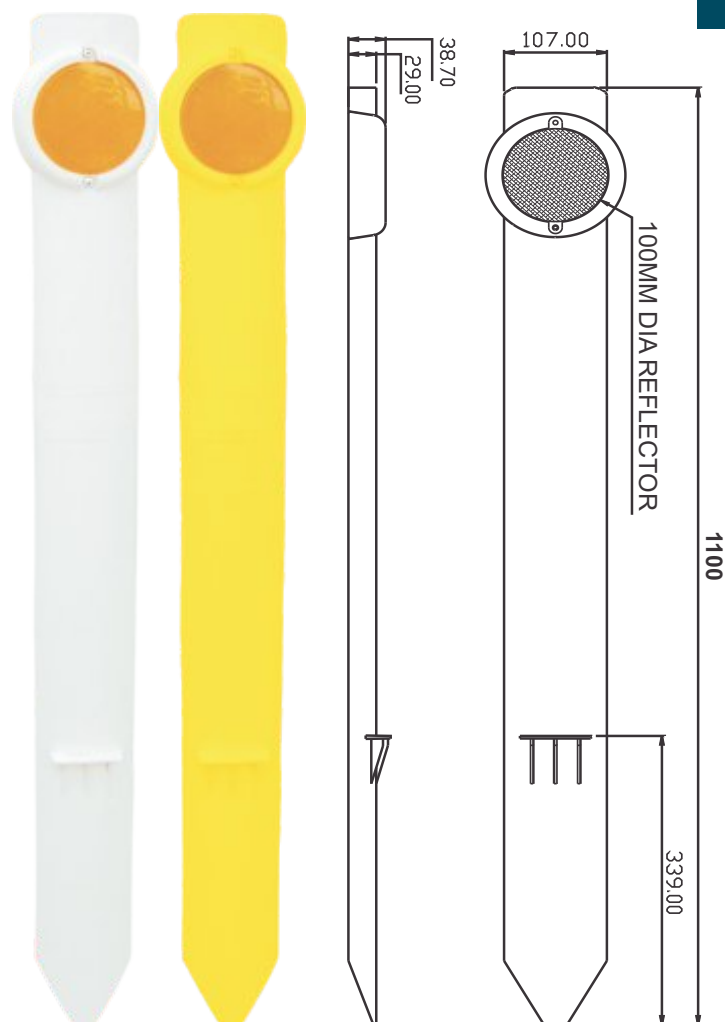

MODEL NO. : DA952 FX

Flexwel Delineators make the dangerous curves, central verges, islands etc more visible to motorists at night and in the daytime.

Made of flexible material, restores back to their erect posture even after minor hits. Fitted with 100 mm PMMA reflector, emits excellent reflection during night time.

They can also be fitted with bi-directional reflectors.

The reflectors are available in: Amber, White or Red color.



FLAP DELINEATORS

Flap Delineators are ideal to separate bus bay, side skip road etc. Its unique design and properties of plastic helps it to maintain its shape and sturdiness even after several hits by vehicles.

Reflective tape on both sides of flap and two reflectors on both sides of base makes it clearly visible from a safe distance.

Designed to be used as a low profile lane divider / channeliser where more obtrusive products are not acceptable

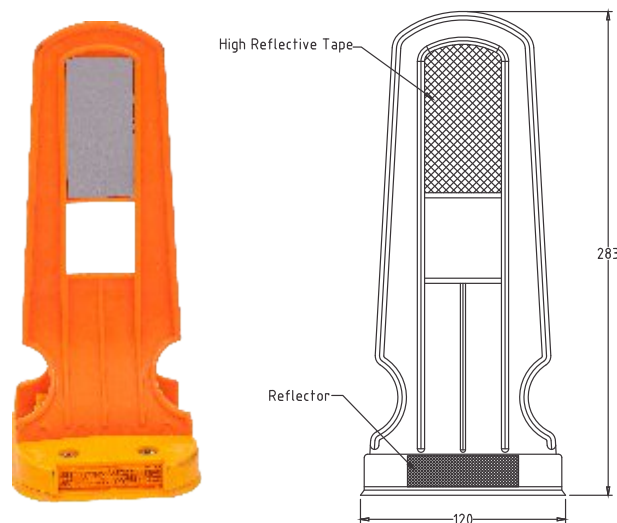

MODEL NO. : DA 806

BOLLARD

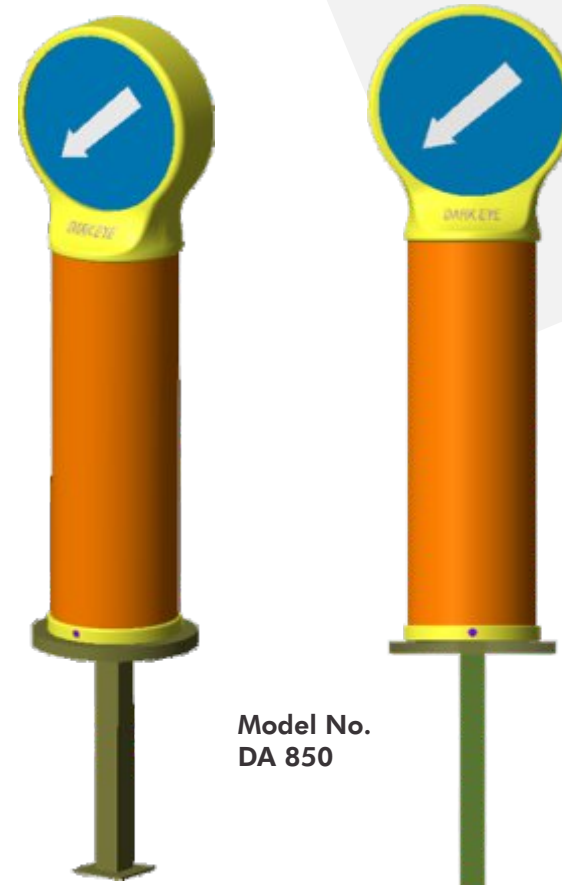

Model No. DA 850

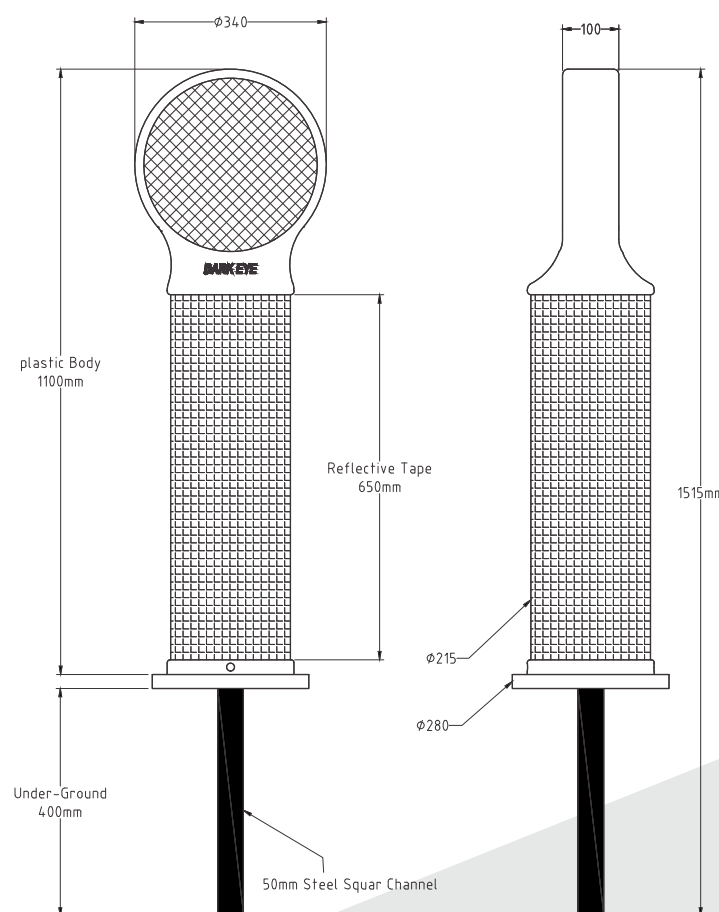

SAFETY BOLLARD

Bollards are used to guide the traffic for safe direction. It is generally installed at the crossing, start of the central verge, diversions etc.

Specifications of Bollard

The bollard consists of One Plastic Square Plate, one MS Round Plate and one message plate fitted on 1825mm MS pipe dia 57mm duly powder coated.

Plastic plate size 385mm x 385mm is fitted with nine reflectors made of PMMA of 100mm dia, welded ultrasonically on Plastic Plate.

MS round plate of 405mm dia, is fitted below the square plate on the MS pipe with the clamps. HIG grade reflective tape in blue color is pasted on the round plate with directional arrow in white color.

MS plate of 305mm x 75mm is fitted below the round plate for messages.

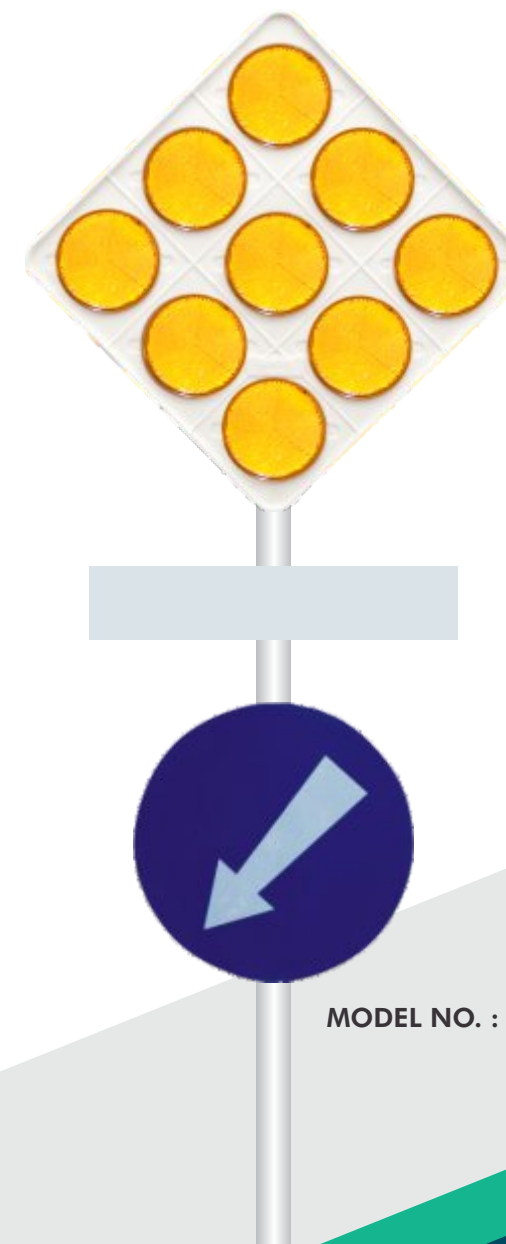

MODEL NO. : DA 952SB

MEDIAN MARKER



MODEL No. : DA 70
WEIGHT : 80 GM

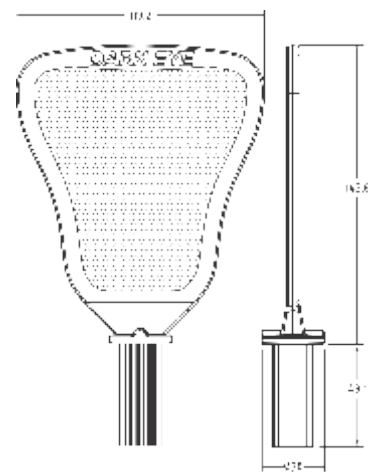

MODEL NO. : DA 72

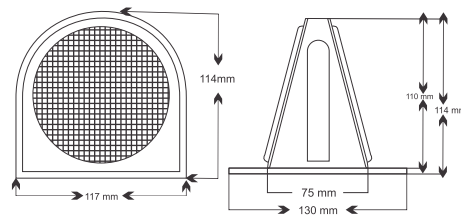

DELINEATORS



MODEL NO. :
DA 952



MODEL NO. :
DA 952 BA

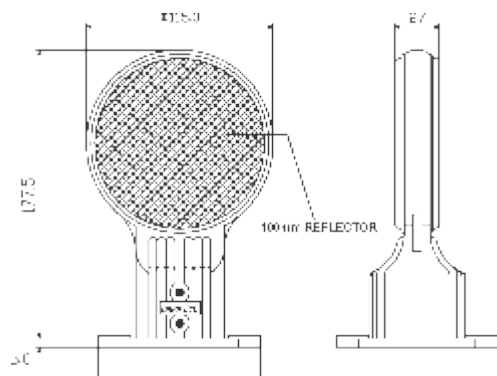

Can be installed on the ground or on the wall.

Best suitable in tunnels, bridges.

It can be installed with epoxy and nails.

Weight : 170 Grams, W/O Base

W BEAM CRASH BARRIER REFLECTOR



MODEL NO. : DA 75

Guard Rail reflectors with metal base is used on the side of crash barrier along the highway. Reflectors can also be fitted on both sides of the metal base. It perfectly delineates the road direction and helps driver in the night driving.



MODEL NO. : DA 952 GR

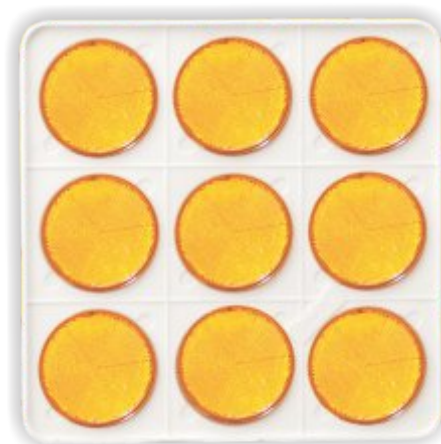

MODEL NO. : DA 812
Size : 400 x 400 mm
9 pcs of 100 mm Reflectors

STUDS



MODEL : DA 110 (DHRUV)



SOLAR STUDS

A more fundamental approach to road and driver safety is now being taken care with the introducing of the DARK EYE Model "DHRUV" solar road stud. These solar - powered environment friendly, LED based Intelligent Road Studs are specifically used to improve safety, reducing accidents on the road by providing information to drivers about the road ahead directly in their natural field of vision.

Solar Road Stud specifically used to save lives and reduce accidents on the road by providing up to a ten-fold increase in visibility, as well as better durability in the most demanding conditions. Solar studs have been able to find a suitable place on approach roads to highest offices in INDIA.

Benefits include:

- Additional "Preview" time for drivers on sharp bends roads. Ability to see road delineation reduced visibility caused by fog, rain or surface spray.
- Visible delineation on wet roads where white lines become invisible due to reflected light.
- These simply installed, maintenance free, highly robust in- pavement studs use state of art SMD technology to effectively convert sunlight using on board solar panels into stored energy.
- Energy consumption is managed using a microprocessor so that just 2 hours of sunshine will provide enough battery to last 4 days - more than enough to ensure the system keep working.

Product Specifications:

- Construction : Aluminum-alloy shell
- 100% water proof design according to IP67.
- Dimension: 125mm x 125mm x 25mm (with a shank of 65mm)
- 100 % waterproof design according to IP 67
- High Efficiency Mono-Crystalline Solar Panel 2.4 V / 0.3 Watt.
- One Ni-Mh or Ni-cd Rechargeable Battery (1.2V / 1600 MA).
- Six Super Bright LEDs with 10,000 to 18,000 mcd (Millicandela).
- View Distance: upto 1000 meters.
- Flash Rate: 2Hz or according to customers requirements
- Bearable Weight: 10 Tons approx
- Color: yellow, red, blue, green or white.
- Working Time: 3 to 4 days after fully charged battery.
- Charging Time: 5 to 6 hours from direct sun light.
- Working Temp: 10° ~ 75° C
- Life Span : three to five years.
- Easy installation, no maintenance
- Unbreakable poly carbonate clear facing designed for maintenance free operation.
- Automatically turns on at night and turns off at dawn.
- High visibility LED's ensure easy and safe night driving.

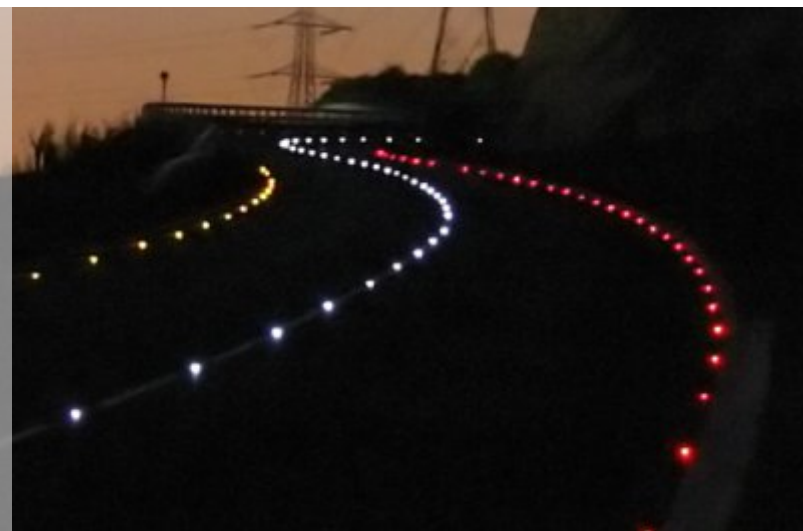

MODEL : DA 111 (JUGNU)

SOLAR STUDS

Dimensions	: 100 x 100 x 25 mm.
Stamp Size	: 50 mm approx
Stamp Dia	: 33 mm
Battery	: 1600 MA / 1.2 volts Ni-Mh
Solar Panel	: Mono-Crystalline 2.4 V / 0.3 Watt.
LEDs	: 4 Nos. Super Bright (2 Nos. each side)
Available Color	: Red, Amber or White
Weight of the Stud	: 450 gms. (approx.)
Working Time	: 4 Days after fully charged battery

Advantage :

- Improves road delineation, particularly effective in poor weather
- Up to 1000 meters visibility Irrespective of head-light efficiency
- Increase driver visibility and awareness to hazards
- Frequency safely outside the epileptic risk zone
- Reliable and compact design
- Bearable Weight: 10 Tons approx
- Clear reference points at ground level
- Improved driver reaction times
- Avoidance of sudden braking and last minute vehicle collision
- Reduces use of headlight high beam
- Alternative to expensive street lighting
- Maintenance free-fully self contained

Key Features :

- Environment friendly Lithium iron battery with more than 2000 charge & discharge circles.
- Round & smooth surface design not only looks elegant, but also can relieve the impact of vehicles.
- Special designed with aluminum shell
- Against subsidence design, preventing the stud from being lower than the ground and losing its effect.

Technical Specifications

- Power Supply: Mono Crystalline Solar Cell (5V 60MA)
- Power Storage Device: Lithium iron battery (3.3V 500MAH)
- Lighting Mode: Flash or Steady lighting
- LED No.: Single Side 3 pcs, double side 6 pcs
- Display Color: Red
- Visual Distance: 1000 m approx
- Working Temperature : -10° C~+70° C
- Starting Intensity: 300 Lux ~ 600 Lux
- Size : Ø125*60mm
- Body Shell Material : Exterior: aluminum; Interior: bullet proof PC
- Weight : 950g approx

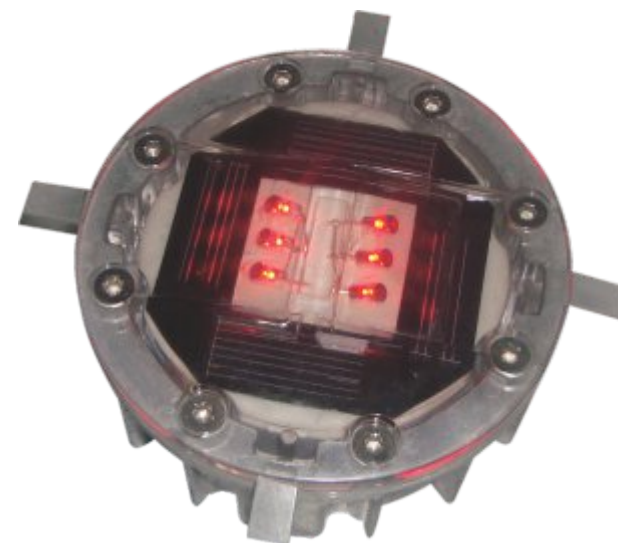

Solar Inpavement Marker

SOLAR STUDS TRANSPARENT



MODEL : DA 113

Advantage :

- Construction : Unbreakable Poly carbonate shell & clear facings designed for maintenance free operation.
- 100% water proof design confirms to IP67
- Dimension: 125 X 125 x 25mm with Dual Shank of 65 mm.
- High Efficiency mono-crystalline Solar panel 3 V / 120 mA.
- One Ni-Mh LSD rechargeable battery (1.2V/800 mA) high temperature
- Six Super bright LEDs with 14,000 mcd.
- View distance: Up to 1000m.
- Flash rate: 2Hz or according to customers requirements
- Bearable weight: 20 Tons.
- Color: Red, Amber, Blue, Green and White .
- Working time: 36 to 40 hours successively after the battery is fully charged.
- The electronic circuit is encapsulated with the battery in the body of the Solar Stud.
- A non-invasive switch (optional) to avoid battery drainage during storage and transportation & the product is approved by IIT, Delhi.
- Charging time: five to six hours/day.
- Working temperature: - 40° ~ 75°C.
- Lifetime: Three to five years.
- Easy installation, no maintenance
- Brightness sensitive auto-switch automatically turns on at night and turns off at dawn.
- High visibility LED's help ensure easy and safe night driving.
- Ideal for highways, parking lots, roads and similar isolated or stand-alone traffic applications



MODEL : DA 112 (SOLAR DELINEATOR)

SOLAR DELINATOR

A superior quality solar delineators, which can be mounted on a pole, cone etc to warn motorists from a distance of an approaching crossovers, flyovers etc.

The delineator provides clear visible guidance in all weather conditions and help to ensure driver safety.

With high quality LED flashing light of this solar delineator proves more receptive to eyes and is visible from a safe distance.

Long lasting, easy to mount makes it user friendly and economical.

Technical Specifications

- Four ultra bright flashing LEDs.
- Available in red or yellow colors.
- Special base for mounting on cone, pole etc.
- High quality reflective solar panel to maximize sun absorption.
- Operating time 3-4 consecutive days (with full charge).

ROAD LAMP

Road Lamps are widely used road safety devices. It serves caution signals to the motorists and pedestrians to avoid accidents during road construction, vehicle break down, at sharp curves on highways etc.

Fully charged battery keeps it blinking for five consecutive days. Light sensor diodes switches off the lamp automatically during the daytime. Its durable and shock proof battery box, built-in automatic light sensor switch, rust-free body, security key feature and portability make it last long.

Solar panel model is also available.

Reflector lense is made of PMMA, bottom & top cover is made of PP material. Weight of road lamp is 760 gms (without battery)

Security key is provided to switch on / off, blink or steady the flash lamp.

It is also use to install \ uninstall the road lamp on any type of construction site, hence making it vandalism proof.

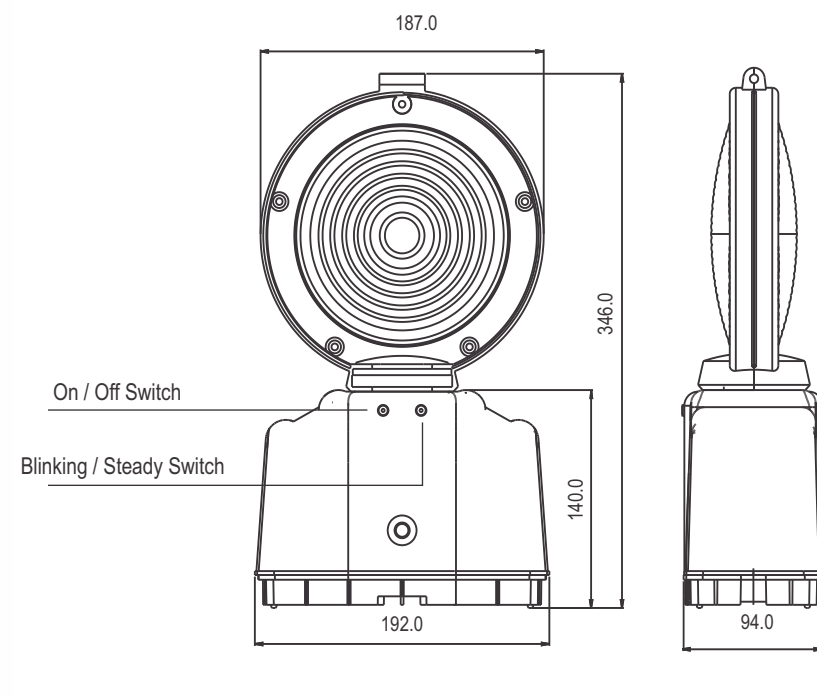

MODEL NO. : DA 105
WEIGHT : 990 Gm
(W/O Battery)



Security Key

ELECTRONIC SAFETY DEVICES

Safety Light Bar is electronically controlled safety device which helps in controlling traffic during night time. Visible from distance in the dark, it provides signal to the distant motorists. LED and fluorescent cast vinyl film in the bar emits highly visible signals. Fitted with flashlight, Light Bar is powered by two battery cells, it can be operated by two-way switch for blinking as well as flash light.

Made of polycarbonate material it is exceedingly durable and crystal clear transparent.

Safety light bar has been designed with electronic chip, equipped with rechargeable battery.

Florescent cast vinyl film is used inside the bar to emit highly visible signals.

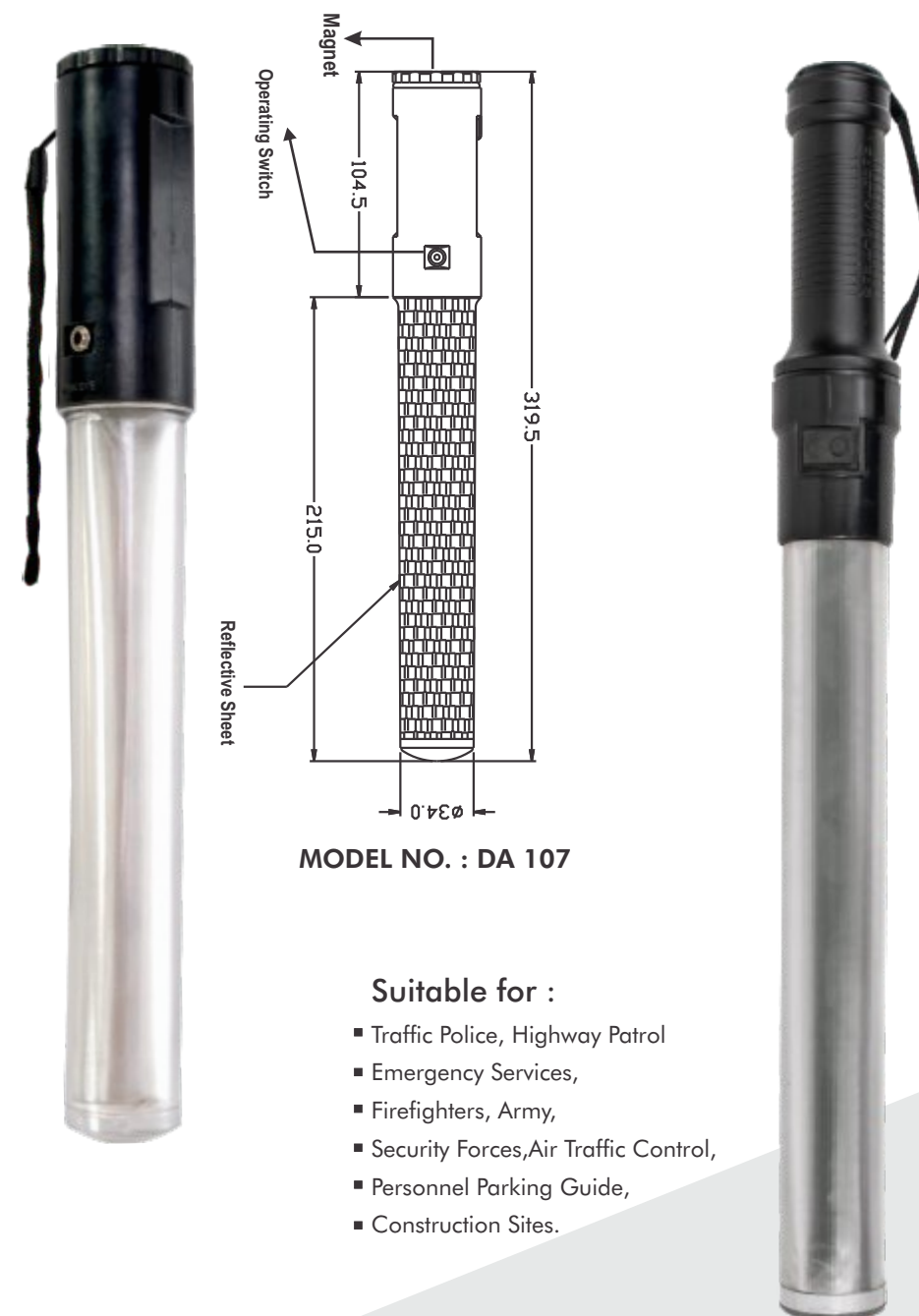

MODEL NO. : DA 107

Suitable for :

- Traffic Police, Highway Patrol
- Emergency Services,
- Firefighters, Army,
- Security Forces, Air Traffic Control,
- Personnel Parking Guide,
- Construction Sites.

MODEL NO. : DA 101

Suitable for :

- Traffic Police, Highway Patrol
- Emergency Services,
- Firefighters, Army,
- Security Forces, Air Traffic Control,
- Personnel Parking Guide,
- Construction Sites.

PARK STUD

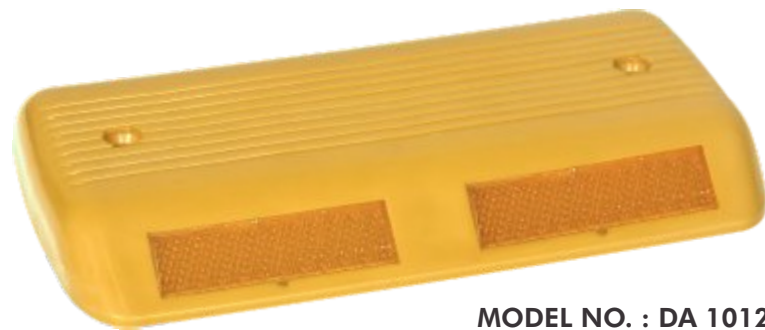

MODEL NO. : DA 1012
Weight : 510 Grams

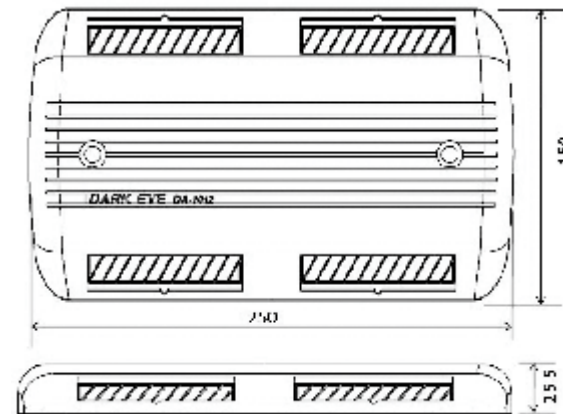

Technical Specifications

- Parking stud is made out of Strong ABS (Astronitrilite Butadiene Styrene) material.
- UV Stabilized and Special material composition to bear the high impact strength.
- Fitted with 4 Nos. of highly Reflective PMMA Reflectors.
- In built 2 holes for fixing with specially designed Nails.
- Dimensions : L – 250mm : W- 150mm : H-25.5mm
- Installation with Epoxy and Nails.

CONE ACCESSORIES



MESSAGE PLATE
Model No : DA 813
Weight : 292 Grams (Only Plate)



SOLAR BLINKER



DELINEATOR

ROAD STUDS

Reflective road studs provide most effective night guidance even under the most adverse weather conditions.

There is a superb range of top quality, dynamically designed studs having excellent quality standards. The studs are visible and can also be heard and felt, due to the rumble when a vehicle crosses over them. Road Studs are available in different sizes to delineate the carriage way both at the center and at the edges of roads.

These are available in aluminium as well as in rigid ABS plastic. The special material composition enables the studs to bear severe impacts.

The specific reflective panel of the studs provides very high reflectivity.



ROAD STUDS



Model - ECO 32 Single Shank
Two Way
Dimensions : 100 x 100 x 26 mm
Plastic body
Reflective Panel - Amber, Red or White
Weight : 140 GM

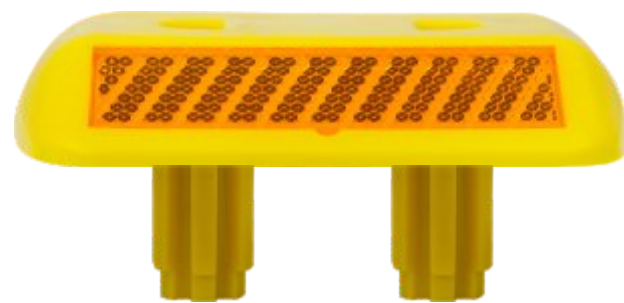
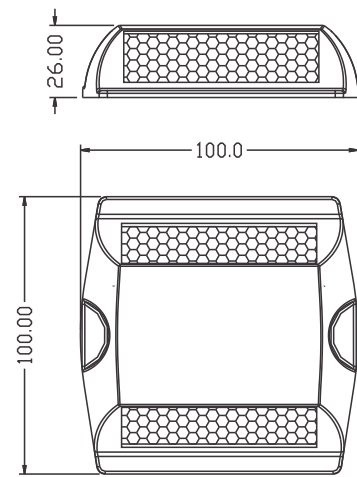

MODEL NO. : DA 52
Two Way Reflective
Available with Single / Double / Without Shank
Weight : 154 GM / 164 GM / 144 GM
Dimensions : 100 x 110 x 20 mm
Plastic body
Reflective panel - Amber, Red or White

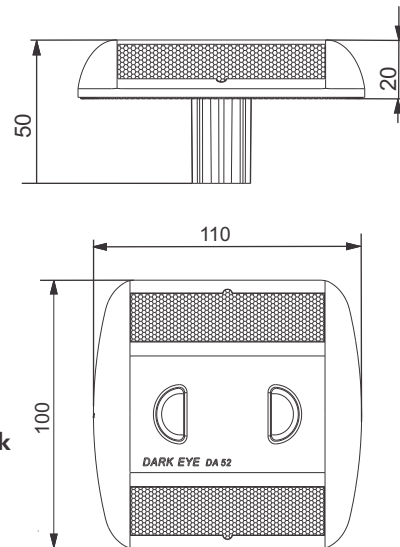

MODEL NO. : DA 971 P
TWO WAY / ONE WAY REFLECTIVE
Dimensions 110 x 128 x 30 mm
Plastic Body Reflective panel
Amber, Red or White

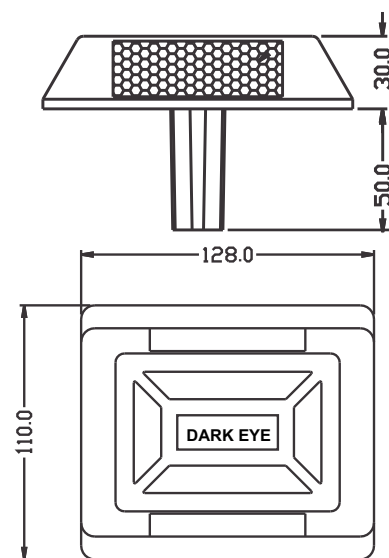

ROAD STUDS



MODEL NO. : DA 972
TWO WAY REFLECTIVE
Dimensions 110 x 120 x 24 mm
Aluminium Alloy body
Reflective Panel- Amber, Red or White
Weight : 435 Grams

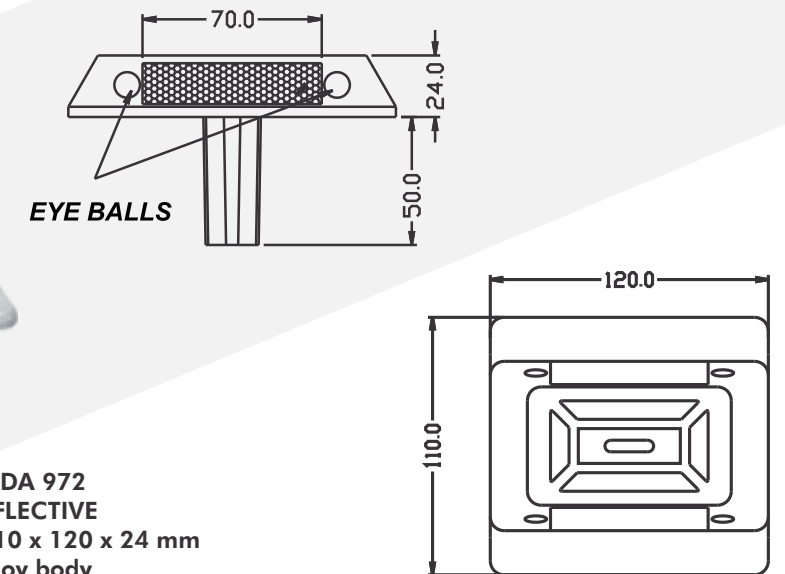

MODEL NO. : DA 971
TWO WAY REFLECTIVE
Dimensions 110 x 128 x 30 mm
Aluminium Alloy body
Reflective Panel- Amber, Red or White
Weight : 530 Grams

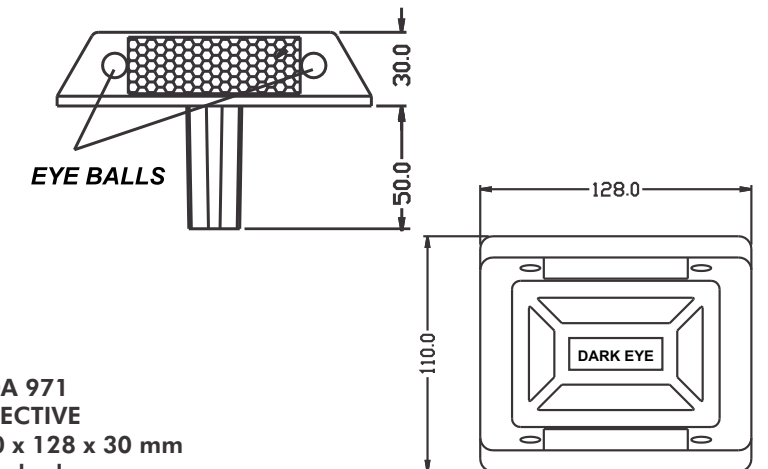

MODEL NO. : DA 53
TWO WAY REFLECTIVE
Dimensions 80 x 105 x 22 mm
Aluminium Alloy body
Reflective Panel- Amber, Red or White
Weight : 312 Grams

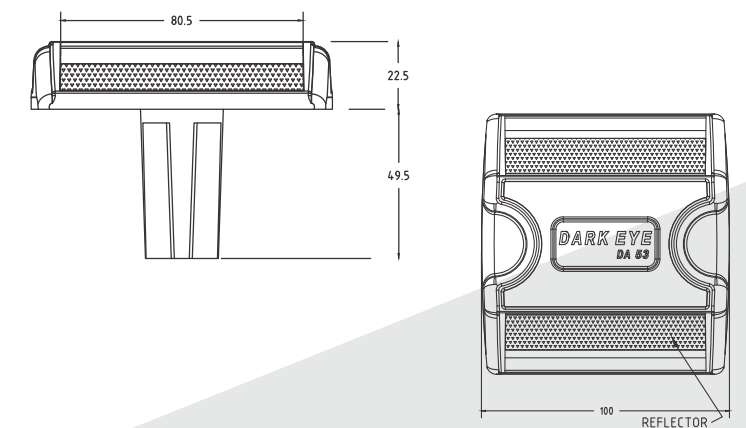

ROAD STUDS



MODEL NO. : DA 972 P

Two Way Reflective
Dimensions 109 x 100 x 20 mm
Plastic Body
Reflective Panel- Amber or Red
Weight : 95 Grams

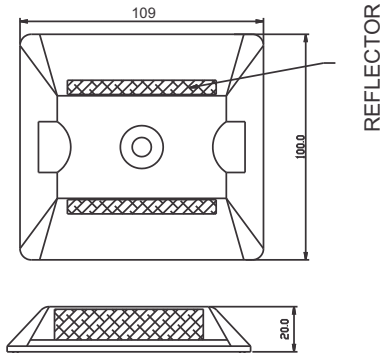

MODEL NO. : DA 978

TWO WAY REFLECTIVE
Dimensions 100 x 100 x 18.5 mm
ABS body
Reflective Panel- Amber, Red or White
Weight : 133 Grams

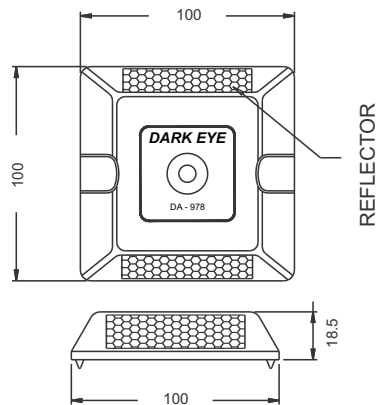

MARKING DOTS



MODEL NO. : DA 979

Two Way Reflective
Dimensions Dia 98 x 17, Plastic body
Reflective panel - Amber or Red
2 x 2 Swarflex glass elements 8mm
Weight : 53 Grams



MODEL NO. : DA 977

Pelli Stud
Dimensions Dia 100 x 16.5,
Plastic body.
Color : Yellow or White



MODEL NO. : DA 980

Reflective Tape 2 HIG Pcs.
Dimensions Dia 98 x 18
Plastic body.
Weight : 70 Grams

SEARCH LIGHTS

Model : DA 120 HELOGEN

The Product is also known as :

- Dragon Light
- Spot Light
- Hunters Light
- Hand Held Light
- Army Light
- Commando Light

Physical Features :

Made from super tough Nylon Glass filled Heavy duty body with avg. wall thickness 2.5 mm. Suitable for all temperature conditions from - 50 deg C to 85 deg C .
Water resistant , shock resistant, crack resistant body. Long life Halogen Bulb with Deep Parabolic reflector .

This reflector does not crack when droplets of water fall on it when search lights is on.

Re-chargeable Sealed Maintenance Free Lead Acid Battery of high performance Integrated handle with Nylon Strap for shoulder resting pad .

Integrated Electronic Circuits with inbuilt charger. The HHSL is light in weight, easy to carry with multiple charging options. Beam of light Reaches upto 1 Km in clear weather conditions.



BACK SIDE
LOW BEAM LED LIGHT
3 BEAMS

**Model :
DA 121 LED SEARCH LIGHT**

Technical Specification :

- Led -3w Powerful
- Black Color
- Weight - 740 gms Approx.
- Range 300m Approx
- Rechargeable Maint. Free battery
- In Built Battery Charger
- Input Voltage 220
- Water resistant
- 3 Step Light
- 8 to 12 hrs continues Operation
- Charging Time 14hrs Approx
- Adjustable Shoulder Strap

Model : DA 122

Power Supply : Ac 220V 50Hz
Built in Battery : 4V 8000 mAh Rechargeable Lead-Acid Battery
Working time : 5 hours
Led : 1 pcs 10W LED on the top
Function : Flashlight

Instruction :

- 1 pcs 10 W high power LED on the top as torch.
- When unit is being charging, the red Led indicator will be on.
- Keep the charging about 12 hours, but should be less than 20 hours.

Cautions :

- When the led bulb is dark during using, that means the battery is at the stage of discharging. In order to protect the battery, please stop using and charge if in time.
- Please do not use it when charging for avoid burning out the interior components of the power source.
- The LED light on the top is very strong, so don't shine to eyes directly.
- Recharge every three months if the light is not used for a long time.
- Keep away from rain or wet.



Q MANAGER (QUEUE)



TELESCOPIC BARRICADING BAR



SAFETY APPARELS

Safety Apparels are designed to Suit the needs of people working in sensitive & Dangerous Areas. It increases the visibility of individual at night & in poor light condition.

The products meet world class quality standards due to the use of high quality standardised materials.



Model - DA 605

Safety Cross Belt
Reflective Tape Colours - White or Lemon
Heat Reflective Tape



Model - DA 601

Reflective Safety Jacket
Colours - Orange, Red or Green
Heat Reflective Tape



PLASTIC CHAIN

Available in various color combinations.
Uses:
Window shade, Glasses chain, Public place,
Clothes line, Exhibition, Dog chain,
Ornament, Toy chain, Parking, Garden

CAUTION TAPE



SAFETY HELMET

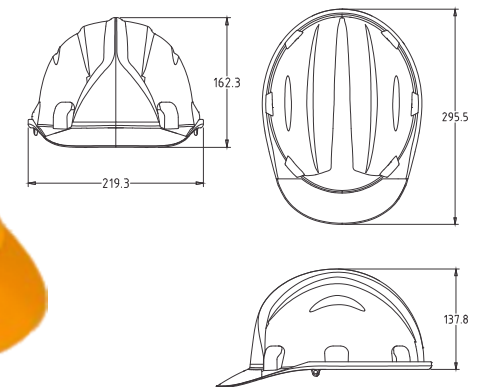

NOSE MASK

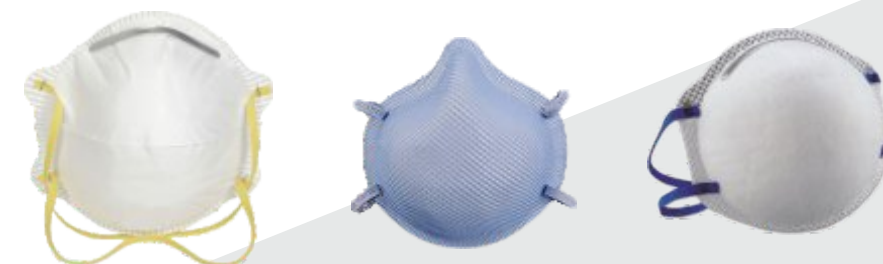

REFLECTORS

Reflectors are skillfully designed to give the maximum reflection and enhance visibility of vehicles during night or bad light conditions.

The high reflection gives the drivers early warning.

The reflectors are fixed to the base plate using ultrasonic welding method which protects the inner reflecting surface from dust, water and humidity giving them Sustained Life.

They never get discoloured because of the UV stabilizer used in their making.

Available in various sizes, these reflectors can be used on either side of all types of vehicles, road barriers and roadsides etc.



MODEL : DA 950



REFLECTORS



Model - DA955
Dimensions - Dia 75 mm
Colours Available :
Red, Amber or White
Weight : 11 Grams



Model - DA 959
Dimensions - 150 x 150 x 150 mm
Colours available - Red, Amber or White
Weight : 75 Grams, Thickness : 9 mm



Model - DA 956
Dimensions - Dia 145 mm
Colours available - Red, Amber or White
Weight : 90 Grams, Thickness - 10 mm



Model - DA970
Dimensions - 70 x 23 mm
Colours Available - Red, Amber or White
with self adhesive tape

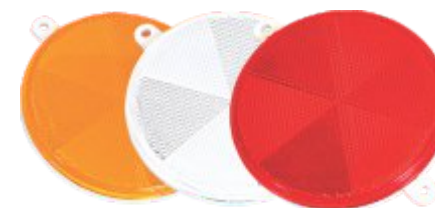

Model - DA957
Dimensions - Dia 109 mm, Thickness - 10mm
Colours Available - Red, Amber or White
Weight : 55 Grams



Model - DA 974
Dimensions - 95 x 50 x 7 mm
Colours Available - Red, Amber or White
Weight : 24 Grams



Model - DA958
Dimensions - 105 x 80 x 7 mm
Colours Available : Red , Amber or White
Weight : 54 Grams



Model - DA975

ROAD SIGNAGES

W BEAM METAL CRASH BARRIERS

CAUTIONARY BOARDS
 MANDATORY BOARDS
 INFORMATION BOARDS
 CANTILEVER BOARDS
 OVER HEAD GANTRY BOARDS

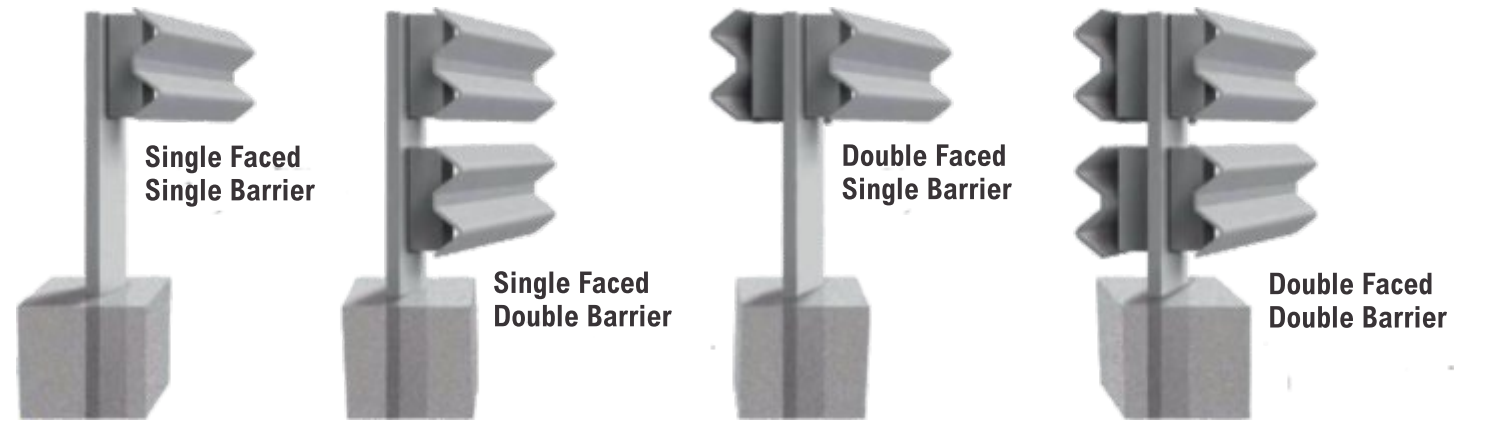
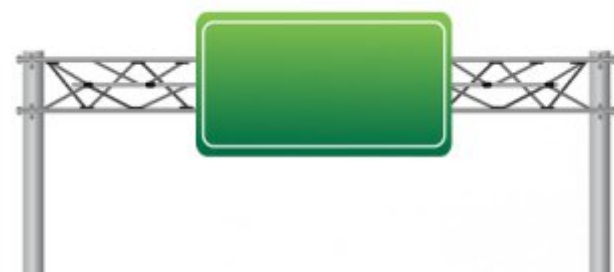
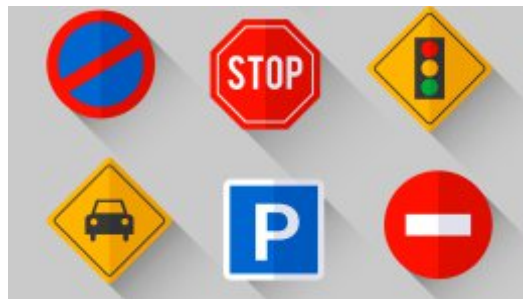
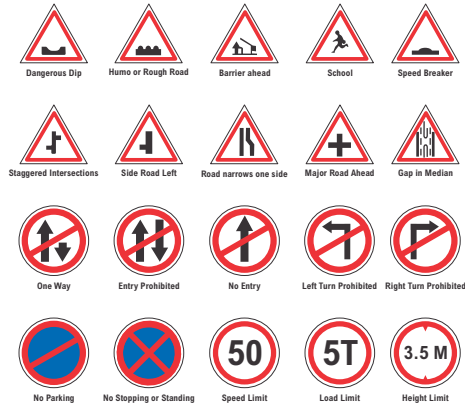

UP COMING PRODUCT

ROLLER CRASH BARRIERS

